



4040

# SINGLE CHIP 4-BIT P-CANNEL MICROPROCESSOR

- Functionally and Electrically Upward Compatible to 4004 CPU
- 14 Additional Instructions (60 total) Including Logical Operations and Read Program Memory
- Interrupt Capability
- Single Step Operation
- 8K Byte Memory Addressing Capability
- 24 Index Registers
- Subroutine Nesting to 7 Levels
- Standard Operating Temperature Range of 0° to 70° C
- Also Available With -40° to +85° C Operating Range

The Intel® 4040 is a complete 4-bit parallel central processing unit (CPU). The CPU can directly address 4K eight bit instruction words or 8K with a bank switch. Seven levels of subroutine nesting, including interrupt, and 24 randomly accessible index registers (24x4) are provided as convenient facilities for the designer. The index registers may be used for addressing or for scratch pad memory for storing computation results. The interrupt feature permits a normal program sequence to be interrupted, with normal program execution continuing after the interrupt service routine is completed. Provisions have also been made to permit single-stepping the CPU using the STOP and ACKNOWLEDGE signals.

The 4040 is an enhanced version of the 4004 and as such retains all the functional capability of that device. It will execute all the 4004 instructions, and is also electrically compatible with all components used with a 4004 CPU.

## BLOCK DIAGRAM

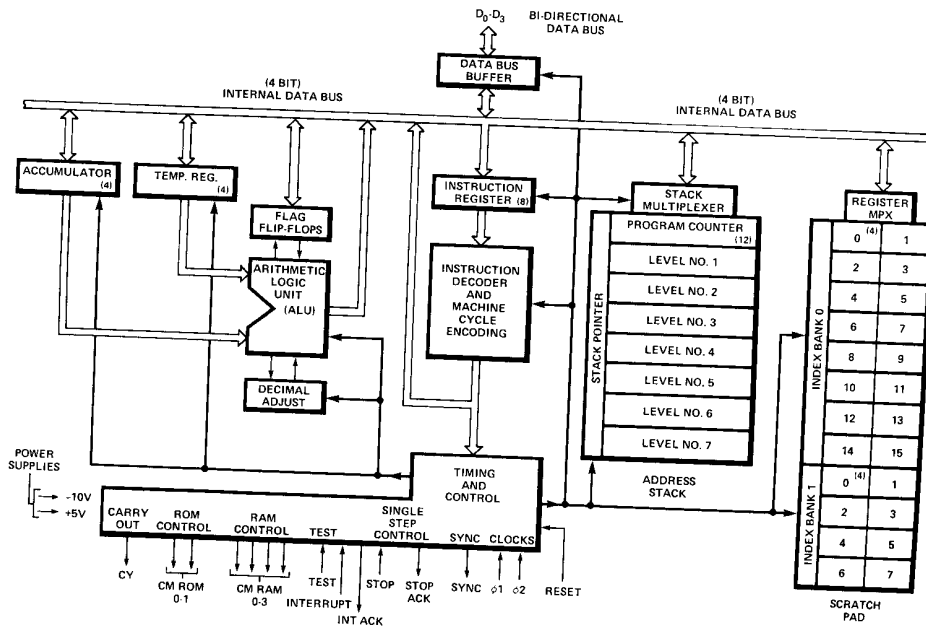

## Pin Description

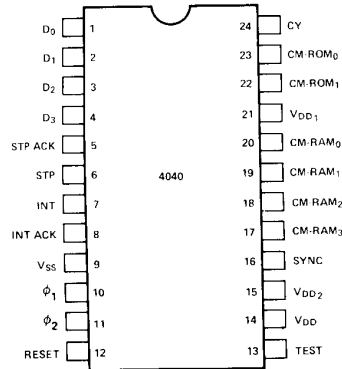

### D<sub>0</sub>-D<sub>3</sub>

**BIDIRECTIONAL DATA BUS.** All address and data communication between the processor and the RAM and ROM chips occurs on these 4 lines.

### STP

**STOP** input. A logic "1" level on this input causes the processor to enter the STOP mode.

### STPA

**STOP ACKNOWLEDGE** output. This signal is present when the processor is in the stopped state. Output is "open drain" requiring pull-down resistor to V<sub>DD</sub>.

### INT

**INTERRUPT** input. A logic "1" level at this input causes the processor to enter the INTERRUPT mode.

### INTA

**INTERRUPT ACKNOWLEDGE** output. This signal acknowledges receipt of an INTERRUPT signal and prevents additional INTERRUPTS from entering the processor. It remains active until cleared by the execution of the new BRANCH BACK and SRC (BBS) instruction. The output is "open drain" requiring a pull-down resistor to V<sub>DD</sub>.

### RESET

**RESET** input. A logic "1" level at this input clears all flag and status registers and forces the program counter to zero. To completely clear all address and index registers, RESET must be applied for 96 clock cycles (12 machine cycles).

### TEST

**TEST** input. The logical state of this signal may be tested with the JCN instruction.

### SYNC

**SYNC** output. Synchronization signal generated by the processor and sent to ROM and RAM chips. It indicates the beginning of an instruction cycle.

### CM-RAM<sub>0</sub> – CM-RAM<sub>3</sub>

**CM-RAM** outputs. These are bank selection signals for the 4002 RAM chips in the system.

### CM-ROM<sub>0</sub> – CM-ROM<sub>1</sub>

**CM-ROM** outputs. These are bank selection signals for program ROM chips in the system.

### CY

**CARRY** output. The state of the carry flip-flop is present on this output and updated each X<sub>1</sub> time. Output is "open-drain" requiring pull down resistor to V<sub>DD</sub>.

$\phi_1, \phi_2$	Two phase clock inputs
V <sub>SS</sub>	Most positive voltage
V <sub>DD</sub>	V <sub>SS</sub> -15V ±5% – Main supply voltage
*V <sub>DD1</sub>	V <sub>SS</sub> -15V ±5% – Timing supply voltage
**V <sub>DD2</sub>	– Output buffer supply voltage

\*For low power operation

\*\*May vary depending on system interface

### Instruction Set Format

#### A. Machine Instructions

- 1 word instruction – 8-bits requiring 8 clock periods (1 instruction cycle)
- 2 word instruction – 16-bits requiring 16 clock periods (2 instruction cycles)

Each instruction is divided into two 4-bit fields. The upper 4-bits is the OPR field containing the operation code. The lower 4-bits is the OPA field containing the modifier. For two word instructions, the second word contains address information or data.

The upper 4-bits (OPR) will always be fetched before the lower 4-bits (OPA) during M<sub>1</sub> and M<sub>2</sub> times respectively.

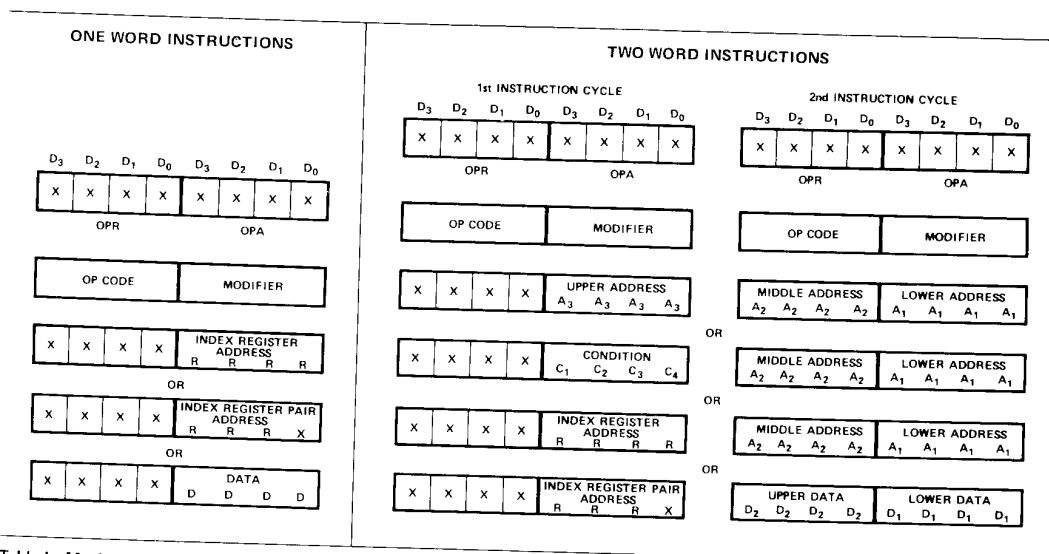

Table I. Machine Instruction Format.

#### B. Input/Output and RAM Instructions and Accumulator Group Instructions

In these instructions (which are all single word) the OPR contains a 4-bit code which identifies either the I/O instruction or the accumulator group instruction and the OPA contains a 4-bit code which identifies the operation to be performed. Table II illustrates the contents of each 4-bit field.

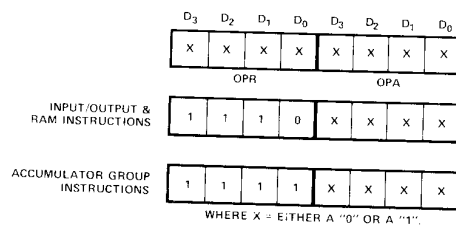

Table II. I/O and Accumulator Group Instruction Formats.

## 4040 Instruction Set

## BASIC INSTRUCTIONS (\* = 2 Word Instructions)

Hex Code	MNEMONIC	OPR D <sub>3</sub> D <sub>2</sub> D <sub>1</sub> D <sub>0</sub>	OPA D <sub>3</sub> D <sub>2</sub> D <sub>1</sub> D <sub>0</sub>	DESCRIPTION OF OPERATION
00	NOP	0 0 0 0	0 0 0 0	No operation.
1 - --	*JCN	0 0 0 1 A <sub>2</sub> A <sub>2</sub> A <sub>2</sub> A <sub>2</sub>	C <sub>1</sub> C <sub>2</sub> C <sub>3</sub> C <sub>4</sub> A <sub>1</sub> A <sub>1</sub> A <sub>1</sub> A <sub>1</sub>	Jump to ROM address A <sub>2</sub> A <sub>2</sub> A <sub>2</sub> A <sub>2</sub> , A <sub>1</sub> A <sub>1</sub> A <sub>1</sub> A <sub>1</sub> (within the same ROM that contains this JCN instruction) if condition C <sub>1</sub> C <sub>2</sub> C <sub>3</sub> C <sub>4</sub> is true, otherwise go to the next instruction in sequence.
2 - --	*FIM	0 0 1 0 D <sub>2</sub> D <sub>2</sub> D <sub>2</sub> D <sub>2</sub>	R R R 0 D <sub>1</sub> D <sub>1</sub> D <sub>1</sub> D <sub>1</sub>	Fetch immediate (direct) from ROM Data D <sub>2</sub> D <sub>2</sub> D <sub>2</sub> D <sub>2</sub> , D <sub>1</sub> D <sub>1</sub> D <sub>1</sub> D <sub>1</sub> to index register pair location RRR.
3 - .	FIN	0 0 1 1	R R R 0	Fetch indirect from ROM. Send contents of index register pair location 0 out as an address. Data fetched is placed into register pair location RRR.
3 -	JIN	0 0 1 1	R R R 1	Jump indirect. Send contents of register pair RRR out as an address at A <sub>1</sub> and A <sub>2</sub> time in the instruction cycle.
4 - --	*JUN	0 1 0 0 A <sub>2</sub> A <sub>2</sub> A <sub>2</sub> A <sub>2</sub>	A <sub>3</sub> A <sub>3</sub> A <sub>3</sub> A <sub>3</sub> A <sub>1</sub> A <sub>1</sub> A <sub>1</sub> A <sub>1</sub>	Jump unconditional to ROM address A <sub>3</sub> A <sub>3</sub> A <sub>3</sub> A <sub>3</sub> , A <sub>2</sub> A <sub>2</sub> A <sub>2</sub> A <sub>2</sub> , A <sub>1</sub> A <sub>1</sub> A <sub>1</sub> A <sub>1</sub> .
5 - --	*JMS	0 1 0 1 A <sub>2</sub> A <sub>2</sub> A <sub>2</sub> A <sub>2</sub>	A <sub>3</sub> A <sub>3</sub> A <sub>3</sub> A <sub>3</sub> A <sub>1</sub> A <sub>1</sub> A <sub>1</sub> A <sub>1</sub>	Jump to subroutine ROM address A <sub>3</sub> A <sub>3</sub> A <sub>3</sub> A <sub>3</sub> , A <sub>2</sub> A <sub>2</sub> A <sub>2</sub> A <sub>2</sub> , A <sub>1</sub> A <sub>1</sub> A <sub>1</sub> A <sub>1</sub> , save old address (up 1 level in stack.)
6 -	INC	0 1 1 0	R R R R	Increment contents of register RRRR.
7 - --	*ISZ	0 1 1 1 A <sub>2</sub> A <sub>2</sub> A <sub>2</sub> A <sub>2</sub>	R R R R A <sub>1</sub> A <sub>1</sub> A <sub>1</sub> A <sub>1</sub>	Increment contents of register RRRR. Go to ROM address A <sub>2</sub> A <sub>2</sub> A <sub>2</sub> A <sub>2</sub> , A <sub>1</sub> A <sub>1</sub> A <sub>1</sub> A <sub>1</sub> (within the same ROM that contains this ISZ instruction) if result = 0, otherwise go to the next instruction in sequence.
8 -	ADD	1 0 0 0	R R R R	Add contents of register RRRR to accumulator with carry.
9 -	SUB	1 0 0 1	R R R R	Subtract contents of register RRRR to accumulator with borrow.
A -	LD	1 0 1 0	R R R R	Load contents of register RRRR to accumulator.
B -	XCH	1 0 1 1	R R R R	Exchange contents of index register RRRR and accumulator.
C -	BBL	1 1 0 0	D D D D	Branch back (down 1 level in stack) and load data DDDD to accumulator.
D -	LDM	1 1 0 1	D D D D	Load data DDDD to accumulator.
F0	CLB	1 1 1 1	0 0 0 0	Clear both. (Accumulator and carry)
F1	CLC	1 1 1 1	0 0 0 1	Clear carry.
F2	IAC	1 1 1 1	0 0 1 0	Increment accumulator.
F3	CMC	1 1 1 1	0 0 1 1	Complement carry.
F4	CMA	1 1 1 1	0 1 0 0	Complement accumulator.
F5	RAL	1 1 1 1	0 1 0 1	Rotate left. (Accumulator and carry)
F6	RAR	1 1 1 1	0 1 1 0	Rotate right. (Accumulator and carry)
F7	TCC	1 1 1 1	0 1 1 1	Transmit carry to accumulator and clear carry.
F8	DAC	1 1 1 1	1 0 0 0	Decrement accumulator.
F9	TCS	1 1 1 1	1 0 0 1	Transfer carry subtract and clear carry.
FA	STC	1 1 1 1	1 0 1 0	Set carry.
FB	DAA	1 1 1 1	1 0 1 1	Decimal adjust accumulator.
FC	KBP	1 1 1 1	1 1 0 0	Keyboard process. Converts the contents of the accumulator from a one out of four code to a binary code.
FD	DCL	1 1 1 1	1 1 0 1	Designate command line.

## 4040 ONLY INSTRUCTIONS

Hex Code	MNEMONIC	OPR			OPA			DESCRIPTION OF OPERATION
		D <sub>3</sub>	D <sub>2</sub>	D <sub>1</sub> D <sub>0</sub>	D <sub>3</sub>	D <sub>2</sub>	D <sub>1</sub> D <sub>0</sub>	
01	HLT	0	0	0 0	0	0	0 1	Executes Halt until interrupt received.
02	BBS	0	0	0 0	0	0	1 0	Return from subroutine and restore SRC.
03	LCR	0	0	0 0	0	0	1 1	Data RAM and ROM bank status loaded into ACC.
04	OR4	0	0	0 0	0	1	0 0	OR accumulator with IR4.
05	OR5	0	0	0 0	0	1	0 1	OR accumulator with IR5.
06	AN6	0	0	0 0	0	1	1 0	AND accumulator with IR6.
07	AN7	0	0	0 0	0	1	1 1	AND accumulator with IR7.
08	DB0	0	0	0 0	1	0	0 0	Select ROM bank 0.
09	DB1	0	0	0 0	1	0	0 1	Select ROM bank 1.
0A	SBO	0	0	0 0	1	0	1 0	Select IR bank 0.
0B	SB1	0	0	0 0	1	0	1 1	Select IR bank 1.
0C	EIN	0	0	0 0	1	1	0 0	Enable interrupt detection.
0D	DIN	0	0	0 0	1	1	0 1	Disable interrupt detection.
0E	RPM	0	0	0 0	1	1	1 0	Load accumulator from 4289-controlled program RAM.

4001/4002/4008/4009/4289  
INPUT/OUTPUT AND RAM INSTRUCTIONS

Hex Code	MNEMONIC	OPR			OPA			DESCRIPTION OF OPERATION
		D <sub>3</sub>	D <sub>2</sub>	D <sub>1</sub> D <sub>0</sub>	D <sub>3</sub>	D <sub>2</sub>	D <sub>1</sub> D <sub>0</sub>	
2 -	SRC	0	0	1 0	R	R	R 1	Send register control. Send the address (contents of index register pair RRR) to ROM and RAM at X <sub>2</sub> and X <sub>3</sub> time in the instruction cycle.
E0	WRM	1	1	1 0	0	0	0 0	Write the contents of the accumulator into the previously selected RAM main memory character.
E1	WMP	1	1	1 0	0	0	0 1	Write the contents of the accumulator into the previously selected RAM output port. (Output Lines)
E2	WRR	1	1	1 0	0	0	1 0	Write the contents of the accumulator into the previously selected ROM output port. (I/O Lines)
E3	WPM	1	1	1 0	0	0	1 1	Write the contents of the accumulator into the previously selected half byte of read/write program memory (used with 4008/4009 or 4289 only)
E4	WR0	1	1	1 0	0	1	0 0	Write the contents of the accumulator into the previously selected RAM status character 0.
E5	WR1	1	1	1 0	0	1	0 1	Write the contents of the accumulator into the previously selected RAM status character 1.
E6	WR2	1	1	1 0	0	1	1 0	Write the contents of the accumulator into the previously selected RAM status character 2.
E7	WR3	1	1	1 0	0	1	1 1	Write the contents of the accumulator into the previously selected RAM status character 3.
E8	SBM	1	1	1 0	1	0	0 0	Subtract the previously selected RAM main memory character from accumulator with borrow.
E9	RDM	1	1	1 0	1	0	0 1	Read the previously selected RAM main memory character into the accumulator.
EA	RDR	1	1	1 0	1	0	1 0	Read the contents of the previously selected ROM input port into the accumulator. (I/O Lines)
EB	ADM	1	1	1 0	1	0	1 1	Add the previously selected RAM main memory character to accumulator with carry.
EC	RD0	1	1	1 0	1	1	0 0	Read the previously selected RAM status character 0 into accumulator.
ED	RD1	1	1	1 0	1	1	0 1	Read the previously selected RAM status character 1 into accumulator.
EE	RD2	1	1	1 0	1	1	1 0	Read the previously selected RAM status character 2 into accumulator.
EF	RD3	1	1	1 0	1	1	1 1	Read the previously selected RAM status character 3 into accumulator.

### 4040 Instruction Codes

Hex	Mnemonic	Hex	Mnemonic	Hex	Mnemonic	Hex	Mnemonic
00	NOP	40	JUN	80	ADD 0	C0	BBL 0
01	HLT	41	JUN	81	ADD 1	C1	BBL 1
02	BBS	42	JUN	82	ADD 2	C2	BBL 2
03	LCR	43	JUN	83	ADD 3	C3	BBL 3
04	OR4	44	JUN	84	ADD 4	C4	BBL 4
05	OR5	45	JUN	85	ADD 5	C5	BBL 5
06	AN6	46	JUN	86	ADD 6	C6	BBL 6
07	AN7	47	JUN	87	ADD 7	C7	BBL 7
08	DB0	48	JUN	88	ADD 8	C8	BBL 8
09	DB1	49	JUN	89	ADD 9	C9	BBL 9
0A	SBO	4A	JUN	8A	ADD 10	CA	BBL 10
0B	SB1	4B	JUN	8B	ADD 11	CB	BBL 11
0C	EIN	4C	JUN	8C	ADD 12	CC	BBL 12
0D	DIN	4D	JUN	8D	ADD 13	CD	BBL 13
0E	RPM	4E	JUN	8E	ADD 14	CE	BBL 14
0F	-	4F	JUN	8F	ADD 15	CF	BBL 15
10	JCN CN=0	50	JMS	90	SUB 0	D0	LDM 0
11	JCN CN=1 also JNT	51	JMS	91	SUB 1	D1	LDM 1
12	JCN CN=2 also JC	52	JMS	92	SUB 2	D2	LDM 2
13	JCN CN=3	53	JMS	93	SUB 3	D3	LDM 3
14	JCN CN=4 also JZ	54	JMS	94	SUB 4	D4	LDM 4
15	JCN CN=5	55	JMS	95	SUB 5	D5	LDM 5
16	JCN CN=6	56	JMS	96	SUB 6	D6	LDM 6
17	JCN CN=7	57	JMS	97	SUB 7	D7	LDM 7
18	JCN CN=8	58	JMS	98	SUB 8	D8	LDM 8
19	JCN CN=9 also JT	59	JMS	99	SUB 9	D9	LDM 9
1A	JCN CN=10 also JNC	5A	JMS	9A	SUB 10	DA	LDM 10
1B	JCN CN=11	5B	JMS	9B	SUB 11	DB	LDM 11
1C	JCN CN=12 also JNZ	5C	JMS	9C	SUB 12	DC	LDM 12
1D	JCN CN=13	5D	JMS	9D	SUB 13	DD	LDM 13
1E	JCN CN=14	5E	JMS	9E	SUB 14	DE	LDM 14
1F	JCN CN=15	5F	JMS	9F	SUB 15	DF	LDM 15
20	FIM 0	60	INC 0	A0	LD 0	E0	WRM
21	SRC 0	61	INC 1	A1	LD 1	E1	WMP
22	FIM 2	62	INC 2	A2	LD 2	E2	WRR
23	SRC 2	63	INC 3	A3	LD 3	E3	WPM
24	FIM 4	64	INC 4	A4	LD 4	E4	WRO
25	SRC 4	65	INC 5	A5	LD 5	E5	WR1
26	FIM 6	66	INC 6	A6	LD 6	E6	WR2
27	SRC 6	67	INC 7	A7	LD 7	E7	WR3
28	FIM 8	68	INC 8	A8	LD 8	E8	SBM
29	SRC 8	69	INC 9	A9	LD 9	E9	RDM
2A	FIM 10	6A	INC 10	AA	LD 10	EA	RDR
2B	SRC 10	6B	INC 11	AB	LD 11	EB	ADM
2C	FIM 12	6C	INC 12	AC	LD 12	EC	RDO
2D	SRC 12	6D	INC 13	AD	LD 13	ED	RD1
2E	FIM 14	6E	INC 14	AE	LD 14	EE	RD2
2F	SRC 14	6F	INC 15	AF	LD 15	EF	RD3
30	FIN 0	70	ISZ 0	B0	XCH 0	F0	CLB
31	JIN 0	71	ISZ 1	B1	XCH 1	F1	CLC
32	FIN 2	72	ISZ 2	B2	XCH 2	F2	IAC
33	JIN 2	73	ISZ 3	B3	XCH 3	F3	CMC
34	FIN 4	74	ISZ 4	B4	XCH 4	F4	CMA
35	JIN 4	75	ISZ 5	B5	XCH 5	F5	RAL
36	FIN 6	76	ISZ 6	B6	XCH 6	F6	RAR
37	JIN 6	77	ISZ 7	B7	XCH 7	F7	TCC
38	FIN 8	78	ISZ 8	B8	XCH 8	F8	DAC
39	JIN 8	79	ISZ 9	B9	XCH 9	F9	TCS
3A	FIN 10	7A	ISZ 10	BA	XCH 10	FA	STC
3B	JIN 10	7B	ISZ 11	BB	XCH 11	FB	DAA
3C	FIN 12	7C	ISZ 12	BC	XCH 12	FC	KBP
3D	JIN 12	7D	ISZ 13	BD	XCH 13	FD	DCL
3E	FIN 14	7E	ISZ 14	BE	XCH 14	FE	-
3F	JIN 14	7F	ISZ 15	BF	XCH 15	FF	-

Second hex  
digit is part  
of jump  
address.

## Absolute Maximum Ratings\*

Ambient Temperature Under Bias	0°C to 70°C
Storage Temperature	-55°C to +125°C
Input Voltages and Supply Voltage with respect to V <sub>SS</sub>	+0.5V to -20V
Power Dissipation	1.0 Watt

**\*COMMENT:**

Stresses above those listed under "Absolute Maximum Ratings" may cause permanent damage to the device. This is a stress rating only and functional operation of the device at these or any other conditions above those indicated in the operational sections of this specification is not implied.

## D.C. and Operating Characteristics

T<sub>A</sub> = 0°C to 70°C; V<sub>SS</sub> - V<sub>DD</sub> = 15V ±5%; t<sub>φPW</sub> = t<sub>φD1</sub> = 400 nsec; t<sub>φD2</sub> = 150 nsec; 4040 V<sub>DD1</sub> = V<sub>DD2</sub> = V<sub>DD</sub>; Logic "0" is defined as the more positive voltage (V<sub>IH</sub>, V<sub>OH</sub>); Logic "1" is defined as the more negative voltage (V<sub>IL</sub>, V<sub>OL</sub>); Unless Otherwise specified.

### SUPPLY CURRENT

Symbol	Parameter	Min.	Limit Typ.	Max.	Unit	Test Conditions
I <sub>SB</sub>	Standby Supply Current (V <sub>DD1</sub> + V <sub>DD2</sub> )		3	5	mA	T <sub>A</sub> = 25°C, V <sub>DD</sub> = V <sub>SS</sub>
I <sub>DD</sub> (total)	Supply Current (V <sub>DD</sub> + V <sub>DD1</sub> + V <sub>DD2</sub> )		40	60	mA	T <sub>A</sub> = 25°C

### INPUT CHARACTERISTICS

Symbol	Parameter	Min.	Limit Typ.	Max.	Unit	Test Conditions
I <sub>LI</sub>	Input Leakage Current			10	μA	V <sub>IL</sub> = V <sub>DD</sub>
V <sub>IH</sub>	Input High Voltage (Except Clocks)	V <sub>SS</sub> -1.5		V <sub>SS</sub> +3	V	
V <sub>IL</sub>	Input Low Voltage (Except Clocks)	V <sub>DD</sub>		V <sub>SS</sub> -5.5	V	
V <sub>ILO</sub>	Input Low Voltage	V <sub>DD</sub>		V <sub>SS</sub> -4.2	V	4040 TEST and INT inputs
V <sub>IHC</sub>	Input High Voltage Clocks	V <sub>SS</sub> -1.5		V <sub>SS</sub> +3	V	
V <sub>ILC</sub>	Input Low Voltage Clocks	V <sub>DD</sub>		V <sub>SS</sub> -13.4	V	

### OUTPUT CHARACTERISTICS

Symbol	Parameter	Min.	Limit Typ.	Max.	Unit	Test Conditions
I <sub>LO</sub>	Data Bus Output Leakage Current			10	μA	V <sub>OUT</sub> = -12V
V <sub>OH</sub>	Output High Voltage	V <sub>SS</sub> -5V	V <sub>SS</sub>		V	Capacitive Load
I <sub>OL</sub>	Data Lines Sinking Current	8	15		mA	V <sub>OUT</sub> = V <sub>SS</sub>
I <sub>OL</sub>	CM-ROM Sinking Current	6.5	12		mA	V <sub>OUT</sub> = V <sub>SS</sub>
I <sub>OL</sub>	CM-RAM Sinking Current	2.5	6		mA	V <sub>OUT</sub> = V <sub>SS</sub>
V <sub>OL</sub>	Output Low Voltage, Data Bus, CM, SYNC	V <sub>SS</sub> -12		V <sub>SS</sub> -6.5	V	I <sub>OL</sub> = 0.5mA
R <sub>OH</sub>	Output Resistance, Data Line "0" Level		150	250	Ω	V <sub>OUT</sub> = V <sub>SS</sub> - .5V
R <sub>OH</sub>	CM-ROM Output Resistance, Data Line "0" Level		320	600	Ω	V <sub>OUT</sub> = V <sub>SS</sub> - .5V
R <sub>OH</sub>	CM-RAM Output Resistance, Data Line "0" Level		1.1	1.8	kΩ	V <sub>OUT</sub> = V <sub>SS</sub> - .5V
R <sub>OH</sub>	INTA, CY, STPA Output Resistance "0" Level		1.1	1.8	kΩ	V <sub>OUT</sub> = V <sub>SS</sub> - .5V

### CAPACITANCE

Symbol	Parameter	Min.	Limit Typ.	Max.	Unit	Test Conditions
C <sub>φ</sub>	Clock Capacitance		17	25	pF	V <sub>IN</sub> = V <sub>SS</sub>
C <sub>DB</sub>	Data Bus Capacitance		7	10	pF	V <sub>IN</sub> = V <sub>SS</sub>
C <sub>IN</sub>	Input Capacitance			10	pF	V <sub>IN</sub> = V <sub>SS</sub>
C <sub>OUT</sub>	Output Capacitance			10	pF	V <sub>IN</sub> = V <sub>SS</sub>

Typical D.C. Characteristics

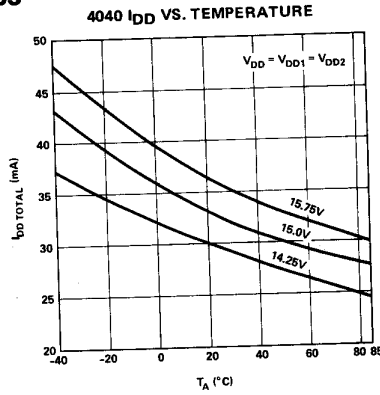

A.C. Characteristics T<sub>A</sub> = 0°C to 70°C, V<sub>SS</sub> - V<sub>DD</sub> = 15V ±5%

Symbol	Parameter	Limit			Unit	Conditions
		Min.	Typ.	Max.		
t <sub>CY</sub>	Clock Period	1.35		2.0	μsec	
t <sub>φR</sub>	Clock Rise Time			50	ns	
t <sub>φF</sub>	Clock Fall Times			50	ns	
t <sub>φPW</sub>	Clock Width	380		480	ns	
t <sub>φD1</sub>	Clock Delay φ <sub>1</sub> to φ <sub>2</sub>	400		550	ns	
t <sub>φD2</sub>	Clock Delay φ <sub>2</sub> to φ <sub>1</sub>	150			ns	
t <sub>W</sub>	Data-In, CM, SYNC Write Time	350	100		ns	
t <sub>WRPM</sub>	Data-In Hold Time-RPM Instruction (X <sub>2</sub> state)	350	100		ns	
t <sub>H</sub> [1,3]	Data-In, CM, SYNC Hold Time	40	20		ns	
t <sub>HRPM</sub>	Data-In Write Time-RPM Instruction (X <sub>2</sub> state)	40	20		ns	
t <sub>H</sub> [3]	Data Bus Hold Time During X <sub>2</sub> - X <sub>3</sub> Transition (I/O Read Instruction only)	150			ns	
t <sub>OS</sub> [2]	Set Time (Reference)	0			ns	
t <sub>ACC</sub> [5]	Data-Out Access Time			930	ns	C <sub>OUT</sub> = 500pF Data Lines
	Data Lines			700	ns	200pF Data Lines <sup>[4]</sup>
	SYNC			930	ns	500pF SYNC
	CM-ROM			930	ns	160pF CM-ROM
	CM-RAM			930	ns	50pF CM-RAM
t <sub>OH</sub>	Data-Out Hold Time	50	150		ns	C <sub>OUT</sub> = 20pF
t <sub>DEL</sub>	CY, STPACK, INTACK Delay			2.0	μsec	

- NOTES:
- t<sub>H</sub> measured with t<sub>φR</sub> = 10nsec.
  - t<sub>ACC</sub> is Data Bus, SYNC and CM-line output access time referred to the leading edge of the next φ<sub>2</sub> clock pulse. t<sub>OS</sub> is the same output access time referred to the leading edge of the next φ<sub>2</sub> clock pulse.
  - All MCS-40 components which may transmit instruction or data to the 4040 at X<sub>2</sub> always enter a float state until the 4040 takes over the data bus at X<sub>3</sub> time. Therefore the t<sub>H</sub> requirement is always insured since each component contributes 10μA of leakage current and 10pF of capacitance which guarantees that the data bus cannot change faster than 1V/μs.
  - C<sub>DATA BUS</sub> = 200pF if 4008 and 4009 or 4289 is used.
  - The 4040 accumulator is gated out at X<sub>1</sub> time at φ<sub>1</sub> leading edge, and the t<sub>ACC</sub> is 930 nsec + t<sub>φD2</sub>.



# 4040

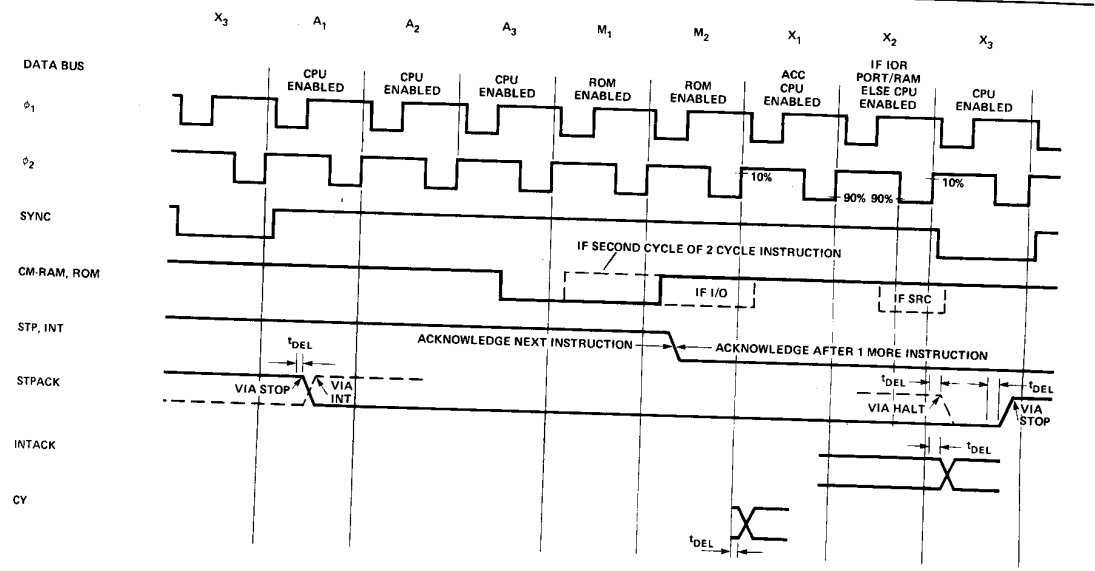

Figure 1. Timing Diagram.

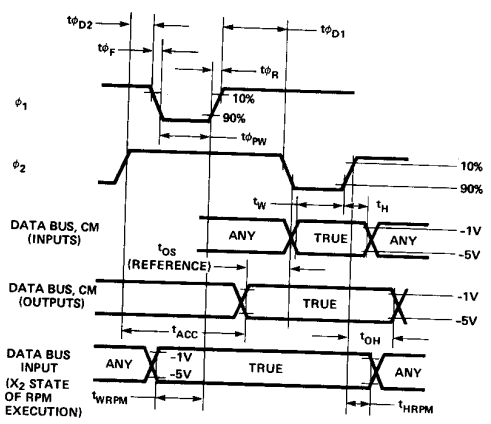

Figure 2. Timing Detail.

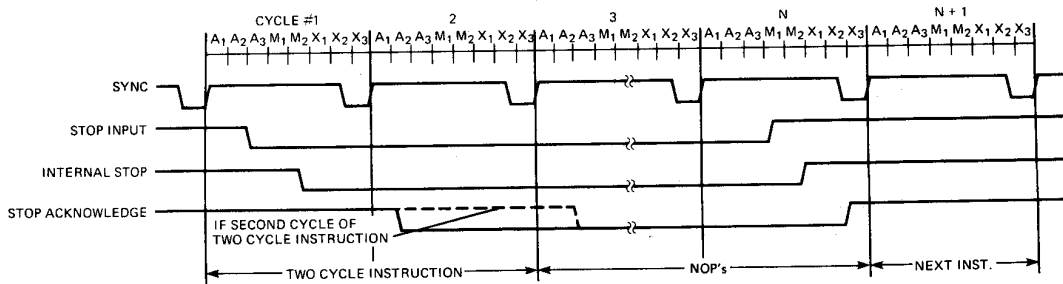

Figure 3. Stop Timing.

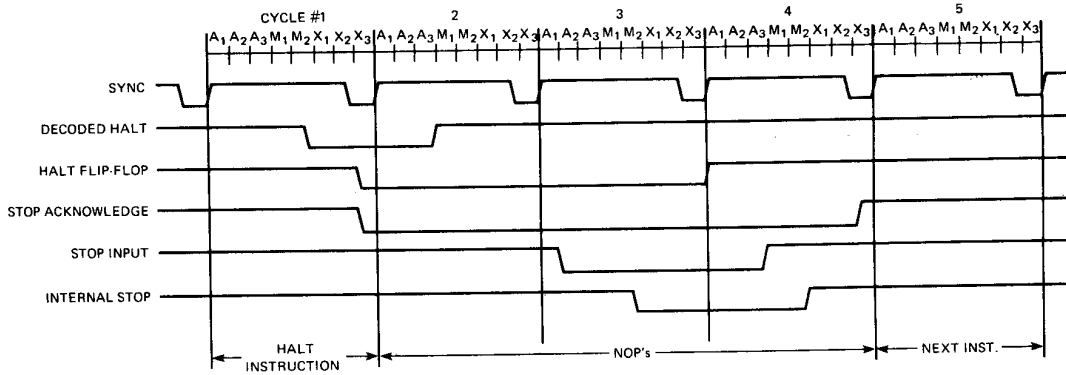

Figure 4. Halt Timing (Exit Using Stop Input).

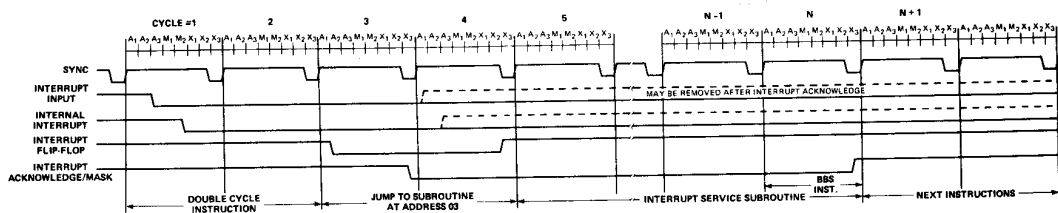

Figure 5. Interrupt Timing.

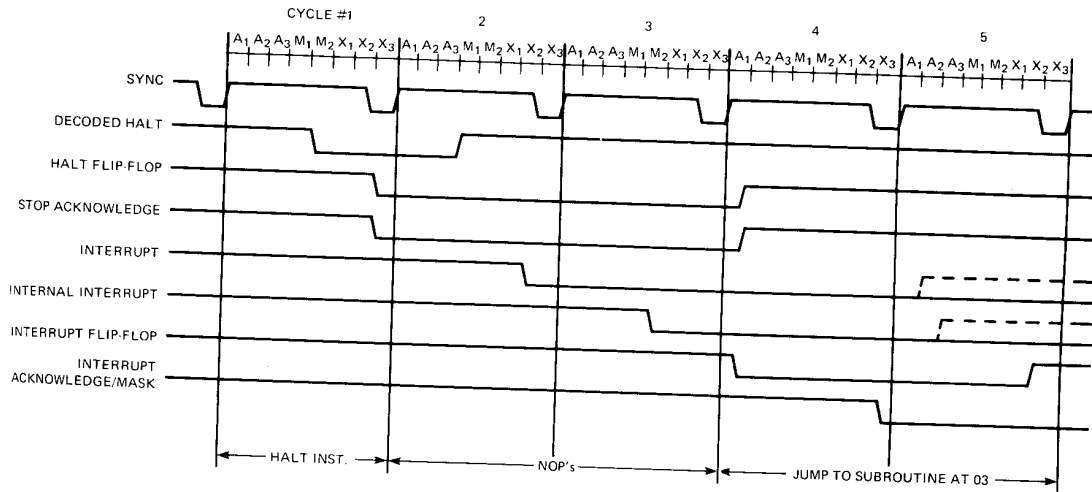

Figure 6. Halt Timing (Exit Using Interrupt).