



# **ATX12VO (12V Only) Desktop Power Supply**

**Design Guide**

---

***Revision 2.01***

***January 2023***



You may not use or facilitate the use of this document in connection with any infringement or other legal analysis. You may not use or facilitate the use of this document in connection with any infringement or other legal analysis concerning Intel products described herein. You agree to grant Intel a non-exclusive, royalty-free license to any patent claim thereafter drafted which includes subject matter disclosed herein.

No license (express or implied, by estoppel or otherwise) to any intellectual property rights is granted by this document.

All information provided here is subject to change without notice. Contact your Intel representative to obtain the latest Intel product specifications and roadmaps.

All product plans and roadmaps are subject to change without notice.

The products described may contain design defects or errors known as errata, which may cause the product to deviate from published specifications. Current characterized errata are available on request.

Intel technologies' features and benefits depend on system configuration and may require enabled hardware, software, or service activation. Performance varies depending on system configuration. No computer system can be absolutely secure. Check with your system manufacturer or retailer or learn more at intel.com.

Intel disclaims all express and implied warranties, including without limitation, the implied warranties of merchantability, fitness for a particular purpose, and non-infringement, as well as any warranty arising from course of performance, course of dealing, or usage in trade.

© Intel Corporation. Intel, the Intel logo, and other Intel marks are trademarks of Intel Corporation or its subsidiaries.

\*Other names and brands may be claimed as the property of others.

Copyright© 2020 - 2023, Intel Corporation. All rights reserved.

# Contents

---

1	Introduction .....	11
1.1	Power Supplies and Alternative Low Power Mode .....	11
1.2	System Power Telemetry Feature.....	12
1.3	References.....	12
1.4	Terminology .....	13
2	Processor Configurations .....	16
2.1	Processor Configurations (Recommended) .....	16
2.2	High End Desktop Market Processor Considerations.....	16
2.2.1	Modular Power Supply Connectors .....	17
2.2.2	Overclocking Recommendations .....	18
3	PCI Express* Add-in Card Considerations .....	19
3.1	PCIe* Add-in Card Power Excursions .....	19
3.1.1	PCIe* Add-in-Card and PSU Power Budgets .....	21
3.1.2	PSU Power Excursion .....	23
3.2	PCIe* AIC Auxiliary Power Connectors.....	24
3.3	PCIe* Add-in-Card Auxiliary Power Connectors Sideband Signals .....	25
3.3.1	Sense1 / Sense0 (Required) .....	25
3.3.2	CARD_PWR_STABLE (Optional) .....	26
3.3.3	CARD_CBL_PRES# (Optional) .....	27
3.3.4	Sideband Signals DC Specifications (Required).....	28
4	Electrical .....	29
4.1	AC Input – REQUIRED .....	29
4.1.1	Input Over Current Protection (Required) .....	29
4.1.2	Inrush Current (Required) .....	29
4.1.3	Input Under Voltage (Required).....	29
4.2	DC Output (Required).....	30
4.2.1	DC Voltage Regulation (Required).....	30
4.2.2	DC Output Current (Required).....	30
4.2.3	Remote Sensing (Optional) .....	31
4.2.4	Other Low Power System Requirements (Required) .....	31
4.2.5	Output Ripple Noise (Required) .....	32
4.2.6	Capacitive Load (Recommended).....	33
4.2.7	Closed Loop Stability (Required).....	33
4.2.8	Multiple 12V Rail Power Sequencing (Required) .....	34
4.2.9	Voltage Hold-Up Time (Required) .....	34
4.3	Timing, Housekeeping, and Control (Required) .....	34
4.3.1	PWR_OK (Required).....	35
4.3.2	PS_ON# (Required) .....	35
4.3.3	+12VSB (Required).....	37
4.3.4	Power-On Time (Required).....	38
4.3.5	Rise Time (Required) .....	38
4.3.6	Overshoot at Turn-On / Turn-Off (Required) .....	39
4.3.7	I_PSU% Signal (Required).....	39
4.4	Reset After Shutdown.....	44
4.4.1	+12VSB at Power-Down (Required) .....	44
4.4.2	+12VSB Fall Time (Recommended).....	44



4.5	Output Protection.....	45
4.5.1	Over Voltage Protection (OVP) (Required).....	45
4.5.2	Short Circuit Protection (SCP) (Required) .....	45
4.5.3	No-Load Situation (Required).....	45
4.5.4	Over Current Protection (OCP) (Required) .....	45
4.5.5	Over Temperature Protection (OTP) (Required) .....	46
4.5.6	Output Bypass (Required).....	46
4.5.7	Separate Current Limit for 12V2 (Optional).....	46
4.5.8	Overall Power Supply Efficiency Levels .....	46
4.5.9	Power Supply Efficiency for Energy Regulations - ENERGY STAR* and CEC PC Computers with High Expandability Score (Recommended) 47	
5	Mechanical.....	49
5.1	Labeling and Marking (Recommended) .....	49
5.2	Connectors (Required).....	50
5.2.1	AC Connector .....	50
5.2.2	DC Connectors .....	50
5.3	Connector from Motherboard to Storage Devices – Reference.....	62
5.3.1	Motherboard Connector .....	62
5.3.2	Serial ATA Connectors (Reference) .....	67
5.4	Airflow and Fans (Recommended).....	69
5.4.1	Fan Location and Direction.....	69
5.4.2	Fan Size and Speed .....	69
5.4.3	Venting .....	69
6	Acoustics .....	71
7	Environmental.....	72
7.1	Temperature (Recommended) .....	72
7.2	Thermal Shock (Shipping).....	72
7.3	Humidity (Recommended) .....	72
7.4	Altitude (Recommended) .....	72
7.5	Mechanical Shock (Recommended) .....	72
7.6	Random Vibration (Recommended).....	73
8	Electromagnetic Compatibility .....	74
8.1	Emissions (Required).....	74
8.2	Immunity (Required).....	74
8.3	Input Line Current Harmonic Content (Optional) .....	74
8.4	Magnetic Leakage Field (Required).....	74
8.5	Voltage Fluctuations and Flicker (Required).....	75
9	Safety .....	76
9.1	North America (Required) .....	76
9.2	International (Required) .....	76
9.3	Proscribed Materials (Required) .....	77
9.4	Catastrophic Failure Protection (Recommended) .....	77
10	Reliability .....	78
10.1	Reliability (Recommended) .....	78
10.2	Reliability – PS_ON# Toggle for S0ix Mode (Required).....	78
11	CFX12V Specific Guidelines 2.0.....	79
11.1	Physical Dimensions (Required) .....	79

12	LFX12V Specific Guidelines 2.0 .....	80
	12.1 Physical Dimensions (Required) .....	80
13	ATX12V Specific Guidelines 3.0 .....	83
14	SFX12V Specific Guidelines 4.0.....	85
	14.1 Lower Profile Package – Physical Dimensions (Required).....	85
	14.2 Fan Requirements (Required) .....	85
	14.3 Top Fan Mount Package – Physical Dimensions (Required) .....	87
	14.4 Fan Requirements (Required) .....	87
	14.5 Reduced Depth Top Mount Fan – Physical Dimensions (Required) .....	89
	14.6 Fan Requirements (Required) .....	89
	14.7 Standard SFX Profile Package – Physical Dimensions (Required) .....	91
	14.8 Fan Requirements (Required) .....	91
	14.9 PS3 Form Factor – Physical Dimensions (Required) .....	93
	14.10 Fan Requirements (Required) .....	93
15	TFX12V Specific Guidelines 3.0.....	95
	15.1 Physical Dimensions (Required) .....	95
	15.2 Mounting Options (Recommended).....	97
	15.3 Chassis Requirements (Recommended) .....	98
16	Flex ATX Specific Guidelines 2.0 .....	100
	16.1 Physical Dimensions (Required) .....	100

## Figures

Figure 3-1: PCI Express* CEM Add-in-Card Power Excursion Limits Chart .....	21
Figure 3-2: Duty Cycle Definition .....	24
Figure 4-1: Differential Noise Test Setup .....	33
Figure 4-2: Power on Timing .....	34
Figure 4-3: PS_ON# Signal Characteristics .....	37
Figure 4-4: +12VSB Power on Timing versus VAC.....	38
Figure 4-5: Rise Time Characteristics .....	39
Figure 4-6: I_PSU% Delay Time Diagram .....	41
Figure 4-7: Recommended Circuit Diagram for I_PSU% signal inside PSU.....	42
Figure 4-8: 12VSB Fall Time .....	44
Figure 5-1: 12VHPWR Connector Labeling Example.....	50
Figure 5-2: 4.2 mm Power Header 10 pin Main Power - Pin Locations.....	51
Figure 5-3: 4.2 mm Power Header 10 pin Main Power – Motherboard Connector, PC Board Layout with Dimensions .....	52
Figure 5-4: 12VHPWR Cable Plug Connector.....	58
Figure 5-5: 12VHPWR Cable Assembly .....	59
Figure 5-6: 12VHPWR Cable Plug Connection Recommendation .....	60
Figure 5-7: 3 mm SATA Power 4 Pin MB Header – Motherboard Connector Diagram (Pin Locations and Latch Location).....	63
Figure 5-8: 3 mm SATA Power 4 Pin MB Header – Recommended PCB Layout (Top Layer View) .....	63
Figure 5-9: 3 mm SATA Power 4 Pin Cable Connector – Key and Pin Locations .....	64
Figure 5-10: 3 mm SATA Power 6 Pin MB Header – Recommended PCB Layout (Top Layer View) .....	65
Figure 5-11: 3 mm SATA Power 6 Pin MB Header – Keying and Pin Locations.....	66

Figure 5-12: 3 mm SATA Power 6 pin/4 SATA Device Cable Diagram (Connector Top View) .....	66
Figure 5-13: 3 mm SATA Power 6 Pin Cable Connector – Traditional Cable Diagram. 66	
Figure 5-14: 3 mm SATA Power 6 Pin Cable Connector – Key and Pin Locations (Bottom View).....	67
Figure 5-15: Serial ATA Power Connector .....	68
Figure 11-1: CFX12V Mechanical Outline .....	79
Figure 12-1: LFX 12V Mechanical Outline.....	80
Figure 12-2: LFX 12V Mechanical Details .....	81
Figure 12-3: LFX 12V PSU Slot Feature Detail .....	81
Figure 12-4: LFX 12V Recommended Chassis Tab Feature .....	82
Figure 13-1: ATX12V Power Supply Dimensions for Chassis Not Requiring Top Venting 83	
Figure 13-2: ATX12V Power Supply Dimensions for Chassis that Require Top Venting 84	
Figure 14-1: SFX12V 40 mm Profile Mechanical Outline .....	86
Figure 14-2: SFX12V Chassis Cutout .....	86
Figure 14-3: SFX12V Top Mount Fan Profile Mechanical Outline .....	88
Figure 14-4: SFX12V Chassis Cutout.....	89
Figure 14-5: SFX12V Recessed Fan Mounting .....	89
Figure 14-6: SFX12V Reduced Depth Top Mount Fan Profile Mechanical Outline.....	90
Figure 14-7: SFX12V Top Mount Fan, Inside enclosure Mechanical Outline (Possible Larger Fan).....	91
Figure 14-8: SFX12V Chassis Cutout .....	91
Figure 14-9: SFX12V 60 mm Mechanical Outline.....	92
Figure 14-10: SFX12V Chassis Cutout .....	93
Figure 14-11: SFX12V PS3 Mechanical Outline .....	94
Figure 15-1: TFX12V Mechanical Outline.....	95
Figure 15-2: TFX12V Dimensions and Recommended Feature Placements (Not to Scale) .....	96
Figure 15-3: TFX12V Power Supply Mounting Slot.....	97
Figure 15-4: TFX12V Fan Right and Fan Left Orientations of Power Supply in Chassis	98
Figure 15-5: Suggested TFX12V Chassis Cutout .....	98
Figure 15-6: TFX12V Suggested Mounting Tab (Chassis Feature).....	99
Figure 16-1: Flex ATX Mechanical Outline .....	100
Figure 16-2: Flex ATX Dimensions and Recommended Feature Placements (Not to Scale) .....	101

## Tables

Table 1-1: Conventions and Terminology .....	14
Table 1-2: Support Terminology .....	15
Table 2-1: Processor Configurations – 12V2 Current .....	16
Table 3-1: PCI Express CEM Add-in Card Power Excursion Limits Table <sup>45</sup> .....	20
Table 3-2: PCIe* AIC and PSU Power Budget used for Peak Power Excursion Test Cases.....	22
Table 3-3: PCIe* AIC and PSU Power Budget used for Peak Power Excursion .....	23
Table 3-4: Duty Cycle Example Test Criteria for a 1000W PSU – RMS.....	24
Table 3-5: Auxiliary Power Connectors Power Supply Rail Requirements - +12V Only	25
Table 3-6: PCI Express* 12VHPWR Connector Power Limits .....	26
Table 3-7: PCI Express* 12VHPWR Connector – Sideband Signal DC Specifications..	28
Table 4-1: AC Input Line Requirements .....	29
Table 4-2: DC Output Voltage Regulation.....	30
Table 4-3: DC Output Transient Step Sizes .....	30

Table 4-4: DC Output Transient Slew Rate .....	31
Table 4-5: Required System DC and AC Power Consumption .....	32
Table 4-6: DC Output Noise/Ripple .....	32
Table 4-7: Output Capacitive Loads .....	33
Table 4-8: Power Supply Timing .....	34
Table 4-9: PWR_OK Signal Characteristics .....	35
Table 4-10: PS_ON# Signal Characteristics .....	36
Table 4-11: I_PSU% Signal Characteristics .....	39
Table 4-12: PCIe AIC and PSU Power Budget used for Peak Power Excursion .....	43
Table 4-13: Duty Cycle Example Test Criteria for a 750W PSU – RMS.....	43
Table 4-14: Duty Cycle Example Test Criteria for a 1000W PSU – RMS.....	43
Table 4-15: Over Voltage Protection.....	45
Table 4-16: Efficiency Load Minimum Requirements.....	46
Table 4-17: Low Load Efficiency Requirements Depending on Overall PSU Size.....	47
Table 4-18: 10W Load Condition (Value in Amps for PSU ≤ 500 Watts) .....	47
Table 4-19: ENERGY STAR* Efficiency versus Load .....	48
Table 4-20: CEC PC Computers with High Expandability Computers <sup>1</sup> - Efficiency versus Load 48	
Table 5-1: 4.2 mm Power Header Main Power Connector Part Numbers .....	50
Table 5-2: Main Power Connector Pinout.....	53
Table 5-3: Extra Board Connector – Required vs. Optional .....	54
Table 5-4: Extra Board Power Connector 6 Pin Connector Pinout.....	54
Table 5-5: +12V Power 4 pin Connector Pinout .....	54
Table 5-6: +12V Power 8 pin Connector Pinout .....	55
Table 5-7: PCIe* 2x3 Auxiliary Power Connector Pin Assignment (75 Watts) .....	55
Table 5-8: PCIe* 2x4 Auxiliary Power Connector Pin Assignment (150 Watts) .....	56
Table 5-9: PCIe* 2x4 Auxiliary Power Connector Sense Pin Decoding by AIC.....	57
Table 5-10: PCIe* 12VHPWR Auxiliary Power Connector Pin Assignment (600 Watts)61	
Table 5-11: Peripheral Connector Pinout.....	61
Table 5-12: 3 mm SATA Power 4 Pin Connector Part Numbers .....	62
Table 5-13: SATA MB Power 4 Pin Connector Pinout.....	63
Table 5-14: 2 SATA Power Cable Part Numbers .....	64
Table 5-15: 3 mm SATA Power 6 Pin Connector Part Numbers .....	65
Table 5-16: +12 V Power 6 Pin Connector Pinout.....	65
Table 5-17: SATA Power Cable Supporting 4 SATA Devices Part Numbers .....	67
Table 5-18: Serial ATA Power Connector Pinout .....	68
Table 6-1: Recommended Power Supply Acoustic Targets .....	71
Table 8-1: EMC Requirement by Country .....	74

## Revision History

Document Number	Revision Number	Description	Revision Date
613768	0.9	<ul style="list-style-type: none"> <li>Initial version</li> </ul>	May 2019
	1.0	<ul style="list-style-type: none"> <li>Section <a href="#">2.1</a> – Added reference of PSU Addendum for all future processor support.</li> <li><a href="#">Table 4-6</a> – Updated 12VSB Ripple and Noise p-pV value to match all other 12V Rails.</li> <li><a href="#">Table 4-8</a> – Added note of where T0 is referenced.</li> <li>Section <a href="#">4.5.9</a>– Updated link of current ENERGY STAR* Computers specification to version 8.0.</li> <li><a href="#">Table 5-1</a> – Updated pin 10.</li> <li>Section <a href="#">5.3</a> – Explained 4 pin and 6 pin SATA Power connection in detail</li> <li>Changed all wording for Alternative Sleep Mode to Alternative Low Power Mode (Although they both reference the same power state, ALPM is more generic).</li> </ul>	May 2020
	1.01	<ul style="list-style-type: none"> <li>Section <a href="#">5.2.2.1</a> – Updated the part number for CviLux*.</li> <li>Updated <a href="#">Figure 5-3</a> to provide more clarification on the connector.</li> </ul>	November 2020
	1.02	<ul style="list-style-type: none"> <li>Section <a href="#">4.2.3</a> – Added extra clarity for use of remote sensing</li> <li>Section <a href="#">5.2.2.1</a> – Updated the part number for Lotes*.</li> <li>Provided clarification about Remote Sensing for the connector.</li> <li>Added <a href="#">Figure 14-7</a> (Different Fan Option for SFX form factor)</li> </ul>	February 2021
613768	1.1	<ul style="list-style-type: none"> <li>Added Section <a href="#">1.2</a>– System Power Telemetry Feature</li> <li>Table 4-17 – Low Load Efficiency previous required levels moved to recommended and new required level is added</li> <li>Added Section <a href="#">4.3.7</a>– System Power (Psys) entire section is new</li> <li>Section <a href="#">5.1</a> – Label of all PSUs should state revision of the specification that it meets</li> <li><a href="#">Table 5-2</a>: Main Power Connector Pinout – Pin 5 is now defined</li> </ul>	March 2022
613768	2.0	<ul style="list-style-type: none"> <li>Updated text for clarity in <a href="#">Section 1</a>: Introduction</li> <li>Updated <a href="#">Section 1.1</a> added second reference for ALPM in <a href="#">Section 4.3.2</a></li> <li>Added new Reference Documentations to list in <a href="#">Section 1.3</a></li> <li>Updated <a href="#">Table 2-1</a>: Processor Configurations – 12V2 Current and reference text for Processors</li> <li>Updated <a href="#">Section 2.2</a> for accuracy and clarity</li> <li>Added ALL of Chapter <a href="#">3</a> – PCIe* AIC Consideration</li> <li>Updated <a href="#">Section 4.2.1</a> and <a href="#">Table 4-2</a> - DC Voltage lower voltage range is changed to 11.2 Volts.</li> <li>Updated DC Output current – Slew rate is increased to meet PCIe CEM requirements, along with max step size <a href="#">Section 4.2.2</a></li> </ul>	March 2022



Document Number	Revision Number	Description	Revision Date
		<ul style="list-style-type: none"> <li>• Table 4-4 added Slew Rate changes based on PSU size</li> <li>• Added last sentence in Section <a href="#">4.2.6</a> for clarification</li> <li>• added about PSU must be able to resume quickly from fast change in PS_ON# signal re-assertion in Section <a href="#">4.3.2</a> last paragraph</li> <li>• Section 4.3.3 - PSUs 1200 watts or larger to have 12VSB rail of 3.0 Amps or larger</li> <li>• Added last sentence to describe when this section would be needed in Section <a href="#">4.5.7</a></li> <li>• Added mention for label of all PSUs should state revision of the specification that it meets and 12VHPWR label for power level supported in <a href="#">Section 5.1</a></li> <li>• Added PCIe* Add-in Card Connector section increased detail for all 3 connector options including new 12VHPWR connector in Section <a href="#">5.2.2.4</a></li> <li>• Changed table at beginning of each section to represent new mechanical size Specification Revision in Chapter <a href="#">11</a>, <a href="#">12</a>, <a href="#">13</a>, <a href="#">14</a>, <a href="#">15</a>, and <a href="#">16</a></li> </ul>	
613768	2.01	<ul style="list-style-type: none"> <li>• Changed top row from 165W to 150W and associated power values to correspond to latest updates in the PSU Design Guide Addendum document <a href="#">Table 2-1</a></li> <li>• Updated Duty Cycle for Peak Events change to match the PSU Test Plan document in <a href="#">Table 3-3</a>.</li> <li>• Updated Whole table updated related to Duty Cycle for Peak Events change to match the PSU Test Plan document <a href="#">Table 3-4</a></li> <li>• Added Note #3 in <a href="#">Table 4-3</a> - that references Dynamic Mode testing for each 12VHPWR Connector in the system</li> <li>• Changed word "Rated" to "Recommended" in the top row of the table in <a href="#">Table 4-4</a></li> <li>• Removed reference to external document in <a href="#">Table 4-10</a> -to Section <a href="#">10.2</a>, which already covered the items listed in this document.</li> <li>• Updated <a href="#">Table 4-12</a> - Duty Cycle for Peak Events changed to match the PSU Test Plan document</li> <li>• Updated <a href="#">Table 4-13</a> and <a href="#">Table 4-14</a> - Whole table updated related to Duty Cycle for Peak Events change to match the PSU Test Plan document.</li> <li>• Added row detailing 80 Plus Silver Efficiency Levels in <a href="#">Table 4-16</a></li> <li>• Added language and details in the table about Required Efficiency levels are now part of how Low Load requirements are defined in Section <a href="#">4.5.8</a> and <a href="#">Table 4-17</a></li> <li>• Added column for 10% Load as defined in ENERGY STAR* for Computers v8 in <a href="#">Table 4-19</a></li> <li>• Changed how 12VHPWR connector power limit labeling can be done. Change from "Required" to "Recommended" for having the 12VHPWR connector power limit on the 12VHPWR connector. Reason is if a PSU uses a modular designs with detachable cables, then the 12VHPWR power limit can be listed on PSU Label. 12VHPWR connector limit must be listed in one of these locations in Section <a href="#">5.1</a></li> </ul>	January 2023

Document Number	Revision Number	Description	Revision Date
		<ul style="list-style-type: none"> <li>• Added mention of two options for 12VHPWR Connector, header changed to "Recommended" for PSUs &gt; 450 watts in Section <a href="#">5.2.2.4.3</a> -</li> <li>• Updated <a href="#">Figure 5-4</a> and <a href="#">Figure 5-5</a> - figures with new pictures of both 12VHPWR connector options</li> <li>• Added paragraph &amp; figure about 12VHPWR Cable Plug Connection Recommendations in Section <a href="#">5.2.2.4.3</a> and <a href="#">Figure 5-5</a></li> </ul>	

§§

# 1 Introduction

---

## This document aligns to ATX12VO Specification Version 2.0

This document provides design requirements for an industry standard focused on single rail power supplies that will meet the existing mechanical size for power supplies while providing the opportunity for higher platform power efficiency. Multi-rail power supply designs have existed for many decades but as computers are evolving a new single main power rail input power is needed to increase efficiency of the power supply.

These single rail power supplies are primarily intended for use with desktop system designs. The key parameters that define mechanical fit across a common set of platforms does not change with existing power supply designs.

This Single Rail Power Supply Design Guide is intended to work for a majority of desktop computer designs. The multi-rail *Intel Desktop Power Supply Design Guide* (Doc#[336521](#)), includes criteria for many different varieties of desktop computers. This document only details what needs to be included in the Single Rail Power Supply Industry standard. The REQUIRED sections are intended to be followed for all systems. The RECOMMENDED sections could be modified based on system design. Lastly, a few sections are labeled as OPTIONAL, which would not be intended for all design but is helpful to some designs.

The specification name for this Power Supply Design is ATX12VO, which stands for ATX 12V Only. If the mechanical size of the power supply is different from ATX, for example SFX then it would be SFX12VO.

This document covers the design parameters for the Power Supply to meet the ATX12VO Specification.

## 1.1 Power Supplies and Alternative Low Power Mode

Computers are continuing to change and introducing new power states. One of these new power states is generically called an Alternative Low Power Mode (ALPM). Some examples of Alternative Low Power Modes are Microsoft\* Windows 10 Modern Standby or Google\* Chrome\* Lucid Sleep. These low power states have created requirements for power supplies. Below is a summary of these requirements as they are mentioned throughout the document. All ALPM features are required in this Single Rail Desktop Power Supply Design Guide.

- Section [4.2.4](#): Other Lower Power System Requirements
  - [To help](#) meet multiple world-wide Energy Regulations the +5VSB standby rail must meet the following efficiency as shown in [Table 4-5](#) which is measured with the main outputs off (PS\_ON# high state). These World-Wide Energy Regulations and standards include: Blue Angel\* system requirements, RAL-UZ 78, US Presidential executive order 13221, ENERGY STAR\*, ErP Lot 6 requirements (2010 and 2013 levels), and 2014 ErP Lot 3 requirements. Additionally, if any Computers use an Alternative Low Power Mode (ALPM) then the +5VSB standby efficiency has similar requirements as shown below.
  - [Table 4-5](#) shows that ALPM requirements are at the 230 mA and 625 mA load levels.

- Section [4.3](#):
  - [Table 4-9](#) “Required” timing values of T1 and T3 support ALPM. Multi rail power supply design guide has the Required T1 and T3 timing values as recommended for ALPM.
- Section [4.2.2](#)– PS\_ON#
- Section [10.2](#):
  - The number of times a PSU toggles on and off is expected to increase.
- Section [4.3.2](#):
  - PSU response quickly to toggling of PS\_ON# signal

## 1.2 System Power Telemetry Feature

When ATX12VO was designed one pin was reserved in the main 10 pin connector for a Telemetry feature. This Telemetry feature is the ability of the power supply to report the percentage of rated power being used by the system. The system components can then react when the power supply rated power limit is reached or exceeded. This is reported as a percentage because power supplies come in many different power ratings and there is no way for the power supply to tell the system its rated power limit. The percentage method allows for a consistent method of telemetry between all ATX12VO power supplies and the system.

The electrical details are explained further in Section [4.3.7](#).

## 1.3 References

The following documents are referenced in various sections of this design guide. For guidelines not specifically mentioned here, refer to the appropriate document.

Document Description	Document Number/Source
IEEE Guide on the Surge Environment in Low-Voltage (1000 V and Less) AC Power Circuits	ANSI C62.41.1-2002
IEEE Guide on Surge Testing for Equipment Connected to Low-Voltage AC Power Circuits	ANSI C62.45-2002
European Association of Consumer Electronics Manufacturers (EACEM*) Hazardous Substance List / Certification	AB13-94-146
American National Standard for Methods of Measurement of Radio-Noise Emissions from Low-Voltage Electrical and Electronic Equipment in the Range of 9 kHz to 40 GHz for EMI testing	ANSI C63.4-2014

Document Description	Document Number/Source
IEC/UL/CSA 62368-1 IEC/UL/CSA 60950-1 EN 60950-1 EU Low Voltage Directive (2014/35/EU) GB-4943 (China) CNS 14336 (Taiwan BSMI) CISPR32/EN55032 (Electromagnetic compatibility of multimedia equipment - Emission requirements) EU EMC Directive (2014/30/EU) CISPR35/EN55035 (Electromagnetic compatibility multimedia equipment Immunity requirements) FCC Part 15 Class B (Radiated and Conducted Emissions)	
PCI Express Card Electromechanical Specification Revision 5.0	PCISIG.com Doc # 15904
PCI Express Card Electromechanical (CEM) Engineering Change Notice (ECN) – “Power Excursion Limits for 300-600w PCIe AICs”	PCISIG.com Doc # 16495
PCI Express Card Electromechanical (CEM) Engineering Change Request (ECR) – “Power Excursion Limits for up to 300 W PCIe AICs”	PCISIG.com Doc # 16680
ENERGY STAR for Computers Version 8.0	<a href="https://www.energystar.gov/products/spec/computers_version_8_0_pd">https://www.energystar.gov/products/spec/computers_version_8_0_pd</a>
European Union Energy Related Products (ErP) Lot 6	<a href="https://ec.europa.eu/energy/en/topics/energy-efficiency/energy-efficient-products/standby">https://ec.europa.eu/energy/en/topics/energy-efficiency/energy-efficient-products/standby</a>
Power Supply Efficiency Labeling Program – 80 plus Organization	80plus.org
Generalized Test Protocol for Calculating the Energy Efficiency of Internal Ac-Dc and Dc-Dc Power Supplies Revision 6.7.1	EPRI – Listed at 80plus.org website
Efficiency (ETA) and Noise (LAMBDA) programs: Cybenetics LTD	Cybenetics.com

## 1.4 Terminology

The below table defines the acronyms, conventions, and terminology that is used throughout the design guide.

**Table 1-1: Conventions and Terminology**

Acronym/Convention/ Terminology	Description
ALPM	Alternative Low Power Mode (ALPM) replaces the traditional Sleep Mode (ACPI S3) and sometime Long Idle [Idle (S0) Display off] with a new lower power mode. An example of ALPM is Microsoft* Modern Standby* or Lucid Sleep with Google* Chrome*
AWG	American Wire Gauge
BA	Declared sound power, LwAd. The declared sound power level shall be measured according to ISO* 7779 for the power supply and reported according to ISO 9296.
CFM	Cubic Feet per Minute (airflow).
Monotonically	A waveform changes from one level to another in a steady fashion, without oscillation.
MTBF	Mean time between failure.
Noise	The periodic or random signals over frequency band of 0 Hz to 20 MHz.
Non-ALPM	Computers that do not use Alternative Low Power Mode use traditional Sleep Mode (ACPI S3).
Overcurrent	A condition in which a supply attempts to provide more output current than the amount for which it is rated. This commonly occurs if there is a "short circuit" condition in the load attached to the supply.
PFC	Power Factor Correction.
p-p	Peak to Peak Voltage Measurement.
PWR_OK	PWR_OK is a "power good" signal used by the system power supply to indicate that the +12VDC outputs are above the under-voltage thresholds of the power supply.
Ripple noise	The periodic or random signals over a frequency band of 0 Hz to 20 MHz.
Rise Time	Rise time is defined as the time it takes any output voltage to rise from 10% to 90% of its nominal voltage.
SELV	Safety Extra Low Voltage - UL 60950-1 states that a SELV circuit is a "secondary circuit, which is so designed and protected that under normal and single fault conditions, its voltages do not exceed a safe value." A "secondary circuit" has no direct connection to the primary power (AC mains) and derives its power via a transformer, converter, or equivalent isolation device
Surge	The condition where the AC line voltage rises above nominal voltage.
VSB or Standby Voltage	An output voltage that is present whenever AC power is applied to the AC inputs of the supply.

**Table 1-2: Support Terminology**

Category	Description
Optional	The status given to items within this design guide, which are not required to meet design guide, however, some system applications may optionally use these features. May be a required or recommended item in a future design guide.
Recommended	The status given to items within this design guide, which are not required to meet design guide, however, are required by many system applications. May be a required item in a future design guide.
Required	The status given to items within this design guide, which are required to meet design guide and a large majority of system applications.

§§

## 2 Processor Configurations

### 2.1 Processor Configurations (Recommended)

The processor power in a desktop computer is provided by the 12V2 power rail of power supplies with multiple power rails. To meet the desktop processor power needs a desktop power supply must provide the current value list in [Table 2-1](#) for the 12V2 voltage rail. [Table 2-1](#) shows the various processor current requirements represented by the desktop processor’s TDP. If a power supply only has one 12V rail, then [Table 2-1](#) shows the amount of current that needs to be dedicated to the desktop processor in a system level power budget.

**Table 2-1: Processor Configurations – 12V2 Current**

PSU 12V2 Capability Recommendations		
Processor TDP	Continuous Current	Peak Current
150 W	33 A	60 A
125 W	26 A	39 A
65 W	23 A	34 A
35 W	11 A	19 A

**NOTES:**

1. If the power supply supports the 240VA Energy Hazard protection requirement, then current levels for the 12 Volt rail above 18 Amps would have to be split into multiple 12V rails.
2. Continuous current is defined for the processors PL2 (Turbo) power limit since desktop processors are expected to stay at PL2 for many seconds, sometimes close to 1 minute. For a PSU any time over 1 second is considered Continuous current.
3. Peak Current is defined for the processor’s PL4 which defines Peak current for a max time of 10 ms.

All future processor power/PSU current requirements will be defined in a document titled *ATX12VO and ATX12V PSU Design Guide Addendum (# 621484)* that is applicable to both Single Rail and Multi Rail ATX Power Supplies. Refer to that document for details of where these values come from.

### 2.2 High End Desktop Market Processor Considerations

The High-End Desktop market requires power supplies with higher power levels than typical mainstream market. The EPS12V specification is often referenced for these designs. The EPS12V specification is a power supply form factor for the server market. This Desktop ATX12VO Single Rail Power Supply design guide includes higher power levels to support these higher performance desktop computers.



## 2.2.1 Modular Power Supply Connectors

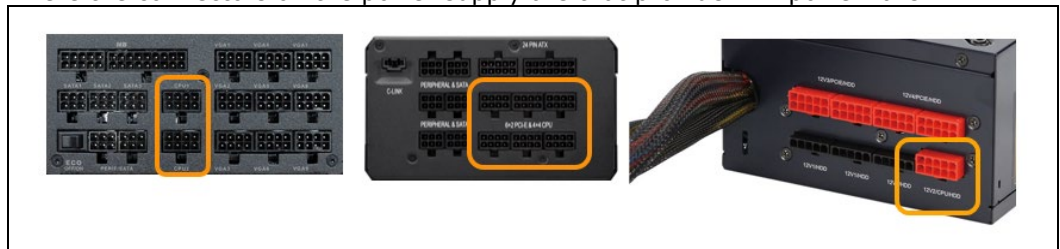
A modular power supply, with multiple detachable cable options is recommended to provide the greatest flexibility to the end user. This approach reduces the chassis volume consumed by unused power cables to improve cable routing and cooling.

The dedicated 12V CPU connectors on the motherboard are either a single 8 pin (2x4) connector, or one or two 4 pin (2x2) connectors, detailed in [Section 5.2.2.3 +12V CPU Power Connector \(Required\)](#). These are often referenced as *EPS12V* connectors.

Section 5.2.2.4 *PCI-Express (PCIe\*) Add-in Card Connector* details three cable/connector options to deliver +12 V power rails to a PCIe\* Add-in Card. While each of the three connectors provides a 12V rail to power the chassis component, they use different pin locations and mechanical keying, and are not directly interchangeable. Therefore, a modular design is an option to support multiple end use configurations.

For example, the end user might require a power supply to support a system with a lower-power or non-overclocked CPU and multiple higher-power graphics cards and thus populate the PSU outputs with multiple power cables configured for the PCIe\* graphics cards. Alternatively, a higher power overclocked CPU system mounting a single, lower power graphics card may require more 12V CPU power and a single plug for PCIe\* power. A modular power supply allows connectors on the power supply to provide 12V power and then the end user can select the appropriately configured cable/plug to provide 12V power in their system with no change to the pinout of the PSU itself.

Here are some examples modular designs. The orange box in each picture identifies where the connectors on the power supply are that provide 12V power rails.



18 AWG wire is typically used to meet the 6-8 Amp/pin requirements of most chassis components. (Example of an exception to this is the 12VHPWR connector that uses 16AWG wires.) Based on this example of 6-8 Amp/pin the following recommendation applies to how much power/current can be supported by each connector determined by the number of +12V pins included in that connector. Using Table 2-1, the number of pins and connectors for motherboard 12V CPU (EPS12V) connectors can be calculated.

- 12-16 A support for 2x2 (4pin) connector
- 18-24 A support for 2x3 (6pin) connector
- 24-32 A support for 2x4 (8pin) connector

A distinction must be made between the current per pin *available* at the PSU through a connector pin and 18 AWG wire vs. the maximum *demand* for current from the connected chassis component such as a PCIe\* Card or motherboard 12V CPU connector(s).

For example, a standard 2x3 PCIe\* power connector supporting a graphics card will draw no more than 6.75 Amps total through its three power pins and two ground pins. Similarly, the 2x4 PCIe\* power connector will draw no more than 13.5 Amps total through three power pins and three ground pins.

It is possible to reduce the number of conductors consumed at the PSU by providing the 12V to a 2x4 PCIe\* card power connector through a 2x2 modular connector at the power supply, for example. Before reducing the conductor count, the PSU designer should also consider the copper losses and the resulting voltage drop incurred by the two cable connectors and a length of the 18 AWG conductor.

This recommendation is based on common design practice. The PSU and system designer may deviate from this guidance but remains responsible for designing the PSU to meet all electrical, thermal, safety and reliability requirements based on the application of the PSU.

It is important to recognize that the new 600W 12VHPWR cable/plug introduced with PCIe\* Gen 5.0 (detailed in [Section 5.2.2.4.3](#)), requires 16 AWG wire and a per-pin current capacity of 9.2 A.

## 2.2.2 Overclocking Recommendations

The power levels listed in Section [2.1](#) - Processor Configurations - RECOMMENDED are for processors that follow the Plan of Record (POR) power levels that include Turbo Mode. If the processor is overclocked, then power requirements will be increased. If the power supply is expected to support end users who intend to overclock then the 12V power rail to the processor should be higher than what is listed in [Table 2-1](#): Processor Configurations.



## 3 PCI Express\* Add-in Card Considerations

---

The PCI Express\* (PCIe\*) Card Electromechanical Specification (CEM Spec) provides thermal, power, mechanical, and signal integrity design guidance for the PCI Express\* Add-in Card (AIC) form factor. This includes the card's electrical and mechanical interface with a host system board, chassis, and power supply.

The 5.0 Revision of the PCIe\* spec introduces four significant updates that directly affect this power supply specification:

1. A Power Excursion allowance was introduced to support brief, high current demands on power, beyond the rated TDP.
2. The maximum power consumption for a single Add-in Card was doubled to 600W. This is the per-card limit from all sources combined.
3. A new 48V (nominal) power rail was added.
4. Two new Auxiliary Power Connectors were introduced to provide the full 600W on a single cable connector. The new *12VHPWR* connector supports 600W on the 12V rail while the *48VHPWR* provides 600W on the 48V rail. Four new sideband signal conductors permit simple signaling between the Add-in Card and power supply.

### 3.1 PCIe\* Add-in Card Power Excursions

PCI Express\* CEM specifications prior to Revision 5.0 did not provide any allowance to permit an Add-in Card to exceed the TDP power for its designated power range. This effectively limited the absolute power consumption of each Add-in Card to a hard limit such as 10 W, 75 W, 150 W, 225 W, or 300 W, even when it would be advantageous for it to make short-duration high-current demands on a power rail.

It is recognized that while many existing PCIe\* CEM products already exceed the card power limits, in violation of prior PCIe\* CEM specs, their power supplies were never explicitly designed to withstand these excursions. Consequently, power excursions beyond these limits, however brief, might cause unexpected card or system malfunctions, potentially triggering PSU overcurrent protection (OCP) or voltage droop. This risk increases when multiple PCIe\* cards are installed in a system.

The PCIe\* CEM 5.0 spec addresses the need for occasional power excursions by permitting the card to briefly exceed the existing limits on supply power while still abiding by the power limits on a time-averaged basis. This allows the power supply and Add-in Card to jointly withstand increased power demands with a limited duration and magnitude.

The PCIe\* CEM 5.0 specification introduces the concept of *Sustained Power*, the average power delivered through a single power cable in a 1-second moving interval. This allows the card and power supply to operate within existing power and thermal envelopes, since the excursions' durations are very short and do not measurably increase the average temperature of any component.

These updates are described in an Engineering Change Notice (ECN) to the PCI Express\* Card Electromechanical (CEM) Specification, Revision 5.0, and will be

integrated into the specification itself in upcoming releases. This ECN is titled “Power Excursion Limits for 300W-600W PCIe\* AICs” (Doc# 16495). This ECN defines power excursions, which are a “temporary condition in which the power exceeds the maximum sustained power”. The ECN states the purpose of the document is to “allow system designers to properly design power subsystems to enable these excursions”. Based on this PCIe\* ECN, this section of the ATX Power Supply Design Guide will provide guidance for power supplies to be designed to meet the permitted power excursions of PCIe\* Add-in Cards.

Note that Add-in Cards with power from 300-600 watts did not exist prior to the PCIe\* CEM 5.0 specification. Earlier generations of PCIe\* Add-in Cards were limited to 300 Watts or below. While many of the relevant specification updates are duplicated here for convenience, designers should confirm that they have the most up to date information by consulting the reference documentation on <https://www.pcisig.com>. The information below is drawn from the PCIe\* documentation at the time of publication of this document.

The power consumption excursions allowed in a PCIe\* Add-in Card rated at 300 watts to 600 watts, only when the mount one of new 12VHPWR or 48VHPWR power connectors, also introduced in PCIe\* CEM 5.0. The 48VHPWR connector is not relevant to this document and therefore will not be discussed further. Similar power excursions are not permitted for the legacy 2x3 and 2x4 PCIe\* Auxiliary Power connectors since that would introduce backward compatibility risks with legacy power supplies.

A second Engineering Change Request, “Power Excursion Limits up to 300 Watts” is under consideration. This ECR would define similar power excursions for the 12VHPWR Auxiliary Power connector for cards less than 300 Watts. It is likely that an identical Power Excursion allowance will be adopted for Add-in Cards rated at 300 W or less, so power supply vendors are advised to provision any 12V rails supporting the 12VHPWR connector with support for Power Excursions at all power levels.

The power supply must be able to provide voltages that remain within the requirements defined in [Table 4-2 \(Section 4.2\)](#) during the defined power excursions. Add-in Card power consumption excursion limits are defined by the maximum ratio (R) of average power consumption in any continuous time interval (T) relative to the maximum sustained (average) power of that Add-in Card.

At all times, the Add-in Card must concurrently adhere to the power excursion limits for all time interval lengths as defined in [Table 3-1](#) and [Figure 3-1](#) as well as the rolling time average of the sustained power of the card. [Table 3-1](#) shows the power excursion limits for all time intervals in which “R” is calculated by dividing the average power consumption in a continuous time interval of length “T” but the maximum sustained power of that Add-in Card. The Add-in Card must also stay within all voltage tolerance and current as defined in [Section 3.2](#) and [Table 3-5](#).

**Table 3-1: PCI Express CEM Add-in Card Power Excursion Limits Table<sup>45</sup>**

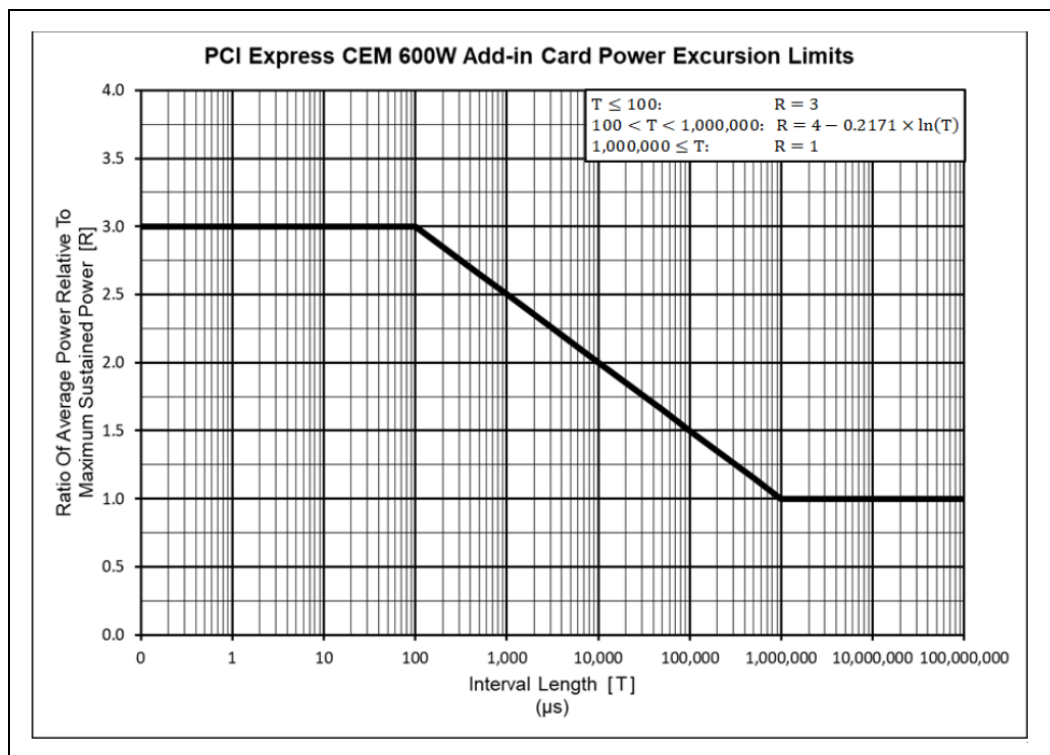
Average Power Calculation Interval Length in microseconds(μs) “T”	Ratio of Average Power <sup>1</sup> in Interval “T” Divided by Maximum Sustain Power	Notes
≤ 100	3	2
>100 and	$4 - 0.2171 \times \ln(T)$	3

Average Power Calculation Interval Length in microseconds( $\mu$ s) "T"	Ratio of Average Power <sup>1</sup> in Interval "T" Divided by Maximum Sustain Power	Notes
<1,000,000 $\mu$ s (1 sec)		
$\geq$ 1,000,000 $\mu$ s (1 sec)	1	-

**NOTE:**

- $R = \frac{\text{average power during internal T}}{\text{Max Sustained Power (ie.TDP)}}$
- This is also the max ratio of instantaneous power relative to maximum sustained power
- $\ln(T)$  is the natural logarithm function
- Add-in Card must at all times and concurrently adhere to power excursion limits for all time interval lengths as well as the limits defined for Power Supply Rail Requirements in [Table 3-5](#).
- Engineering Change Notice for up to 300 Watts (Work in Progress) will likely make this table apply to all cards mounting the 12VHPWR connector.

Figure 3-1: PCI Express\* CEM Add-in-Card Power Excursion Limits Chart



### 3.1.1 PCIe\* Add-in-Card and PSU Power Budgets

Three dominant power demands dictate the total system power provisioning:

- CPU power consumption

2. PCIe\* Add-in Card power level
3. Rest-of-Platform power demand

Rest-of-Platform (ROP) collectively includes anything in a system (memory, storage, motherboard, peripherals, etc.) not including the PCIe\* Add-in Cards or CPU. [Table 3-2](#) provides examples that generally balance these three power demands to obtain an overall PSU power rating. The PCIe\* power entries in the table are standard power levels for PCIe Add-in Cards defined in the PCIe\* CEM 5.0 Specification. As a consequence of the introduction of 450W and 600W Card power levels, the wide range of possible PCIe\* card power demands plays a dominant role in setting total platform power supply ratings.

These configurations will also serve as test cases for evaluating power supply excursions. The peak power demands of the PCIe\* Add-in Cards at each power level can guide the peak power demands of the PSU.

In cases where a PCIe\* Add-in Card has a sustained power not listed, use these values as a minimum value for all cards up to these power levels. The table below is seen as a minimum power level based on Rest of Platform (ROP) power. The ROP assumptions are shown in [Table 3-2](#) below. If a system designer plans more ROP power, the overall platform power budget for a system must be increased. If a system designer plans less ROP power, then the PSU size can also decrease. In the case of ROP values lower than what is shown in [Table 3-2](#), the calculations should be done for Peak Power Requirement for this specific system. If the Peak Power requirements for this specific system exceed the values shown in [Table 3-2](#) than a PSU with support for higher peak power levels would be needed.

The CPU continuous power comes from [Table 2-1](#), taking the current value and multiplying by 11.2 Volts to create a power value and round up slightly. The CPUs used in these examples are the 65w TDP for the first row and 125w TDP for all other rows.

This is a recommendation for a Power Budget and guidance that is needed to define PSU Peak Power Excursion levels. These power budgets also assume only one PCIe\* Add-in Card will use these power excursions. If more than one PCIe\* Add-in Card is installed in the system, then the system designer needs to verify the power supply can provide enough power for all components in the system including the Peak Power Excursions of all components. This industry standard PSU Design Guide does not provide a standard definition for that type of system design.

**Table 3-2: PCIe\* AIC and PSU Power Budget used for Peak Power Excursion Test Cases**

PCIe* AIC Power	CPU Continuous Power	Rest of Platform	PSU Rated PSU Size
75	275	100	450
150	300	100	550
225	300	125	650
300	300	150	750
450	300	250	1000
600	300	300	1200

**NOTES:**

1. Rest of Platform power here will not apply to all systems.
  - a. If Rest of Platform power is higher than what is in the table, increase the PSU size respectively.
  - b. If Rest of Platform power is lower than what is listed in the table the PSU size can also be reduced, but Peak Power requirements are also expected to increase beyond what is listed in [Table 3-3](#).
2. CPU Power and Rest of Platform Power can vary from this table which would result in custom Peak Power requirements

### 3.1.2 PSU Power Excursion

Based on the power budgets in [Table 3-2](#) and peak power of both the Processor detailed in [Table 2-1](#) and the PCIe\* Add-In-Cards in Section [3.1](#), the following Peak Power Requirements are defined for the Power Supply. The peak time for each power level is defined in [Table 3-3](#). The PCIe\* Add-in card power excursions are only designed for the new 12VHPWR connector. Therefore, the table is split into two different power levels where it is expected that power supplies greater than 450 Watts will have at least one 12VHPWR connector.

**Table 3-3: PCIe\* AIC and PSU Power Budget used for Peak Power Excursion**

Power Excursion % of PSU Rated Size PSU ≤ 450 Watts & PSUs without 12VHPWR Connector	Power Excursion % of PSU Rated Size PSU > 450 Watts & 12VHPWR Connector present	Time for Power Excursion (TE)	Testing Duty Cycle
150%	200%	100 μs	5%
145%	180%	1 ms	8%
135%	160%	10 ms	12.5%
110%	120%	100 ms	25%
100%	100%	Infinite	--

**NOTES:**

1. Peak Power defined in this table correspond to Platform Level Power Budgets described in [Table 3-2](#), if CPU or Rest of Platform power is reduced from [Table 3-2](#) to reduce PSU size, then custom Power Excursion % of PSU rated size must also be calculated.
2. This Table is only applicable if a power supply does not provide the I\_PSU% signal. As I\_PSU% is required for ATX12VO power supplies refer to Section [4.3.7](#), refer [Table 4-2](#) for an updated table.

The Testing Duty Cycle is not defined in the PCIe\* CEM Gen 5.0 ECN, but it must be defined to create a test criteria specific to a power supply. The Testing Duty Cycle defines the percentage of time the Power Excursion value peaks with the remainder of the time defined as a Time\_Constant (T<sub>c</sub>). The Power Level defined is to have the RMS value during this Dynamic Load test to be the Rated Wattage of the Power Supply. [Table 3-4](#) shows an example of how the testing criteria for power excursions of 1000 Watt Power Supply using an RMS value to average the rated power of a power supply. This calculation is the same as what is described in the PCIe\* CEM Gen 5 Power Excursion ECN. For all power supplies with a rated wattage different than 1000 watts a similar RMS calculation needs to be performed.

Figure 3-2: Duty Cycle Definition

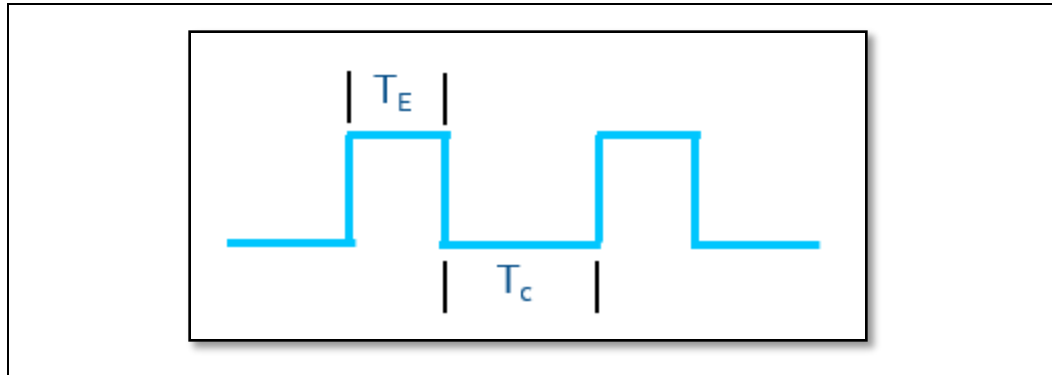


Table 3-4: Duty Cycle Example Test Criteria for a 1000W PSU – RMS

Duty Cycle	Time for Power Excursion ( $T_E$ )	Time Constant ( $T_C$ )	Power @ $T_E$	Power @ $T_C$
5%	1900 $\mu$ s	100 $\mu$ s	918 W	2000 W
8%	11.5 ms	1 ms	897 W	1800 W
12.5%	70 ms	10 ms	882 W	1600 W
25%	300 ms	100 ms	924 W	1200 W

**NOTES:**

1. The Capacitive Load mentioned in [Table 4-6](#) is expected to be applied to this test scenario.
2. Total Test time for each Power Excursion testing time is expected to last until thermal saturation occurs in the PSU.
3. More details about test time for each row above and formulas to calculate  $T_C$  and  $T_E$  power values for different PSU sizes will be detailed in the "Desktop Platform Form Factor Power Supply Test Plan – Doc # [338448](#)
4. This Table is only applicable if a power supply does not provide the I\_PSU% signal. As I\_PSU% is required for ATX12VO power supplies refer to [Section 4.3.7](#), see [Table 4-13](#) or [Table 4-14](#) for an updated table.

### 3.2 PCIe\* AIC Auxiliary Power Connectors

The PCIe\* CEM 5.0 specification defines three 12V Auxiliary Power Connectors to be used with PCIe\* Add-in Cards

1. 75 W 2x3 connector
2. 150 W 2x4 connector
3. 600 W 2x6 12VHPWR connector (new in PCIe\* 5.0)

Section [5.2](#) specifies the Mechanical information for all 12-volt Connectors. Note that the Voltage Tolerance listed below is different from this Power Supply Design Guide for the Low voltage tolerance [Table 4-2](#), the reason for the difference is allowing for voltage drop on a motherboard from the Main Power Connector to the motherboard to the PCIe\* Edge Card Connector. [Table 3-5](#) shows the voltage tolerance required to the PCIe\* Add-in Card at both the motherboard edge card connector and Auxiliary



Power connectors. Each Auxiliary Power Connector must have voltage pins that belong to the same +12V power converter if multiple voltage rails exist from the PSU.

**Table 3-5: Auxiliary Power Connectors Power Supply Rail Requirements - +12V Only**

+12V Power Rail Characteristic	2x3 Connector	2x4 Connector	12VHPWR Connector
Sustained Power <sup>2, 4, 5</sup>	75 Watts	150 Watts	600
+ 12 V Voltage Range	+5% / -8%	+5% / -8%	+5% / -8%
Current <sup>3, 4, 5</sup> (Max RMS)	6.75 Amps	13.5 Amps	55 Amps <sup>1</sup>

**NOTES:**

1. The maximum current slew rate for the 12VHPWR connector interface shall be no more than 5.0 A/μs.
2. Maximum sustained power is an average power in any continuous 1 second interval
3. Maximum of root-mean-square (RMS) of current in any continuous 1 second interval
4. The main reference limit is the maximum allowed sustained power per connector and Add-in Card type. Add-in Card and System must concurrently comply with all power and voltage and current requirements in this table for the applicable connector and other requirements in this specification for the Add-in Card type.
5. Maximum instantaneous and other excursions exceeding these limits are defined in Section [3.1](#) of this document.

### 3.3 PCIe\* Add-in-Card Auxiliary Power Connectors Sideband Signals

The new 12VHPWR connector has 4 sideband signals defined that communicate between the Power Supply and the PCIe\* Card. Two of these sideband signals are required with the connector and two of them are optional from the Power Supply. The four sideband signals are:

- SENSE0
- SENSE1
- CARD\_PWR\_STABLE
- CARD\_CBL\_PRES#

For the most up to date and detailed description, refer to Section [5.3](#) – Optional Sideband Signal in the **PCI Express\* Card Electromechanical Specification, Rev 5.0**. That document is available from [www.pcisig.com](http://www.pcisig.com).

#### 3.3.1 Sense1 / Sense0 (Required)

These two sideband signals provide important information from the PSU to the Add-in Card and are therefore required from the power supply. These signals allow the PSU to tell the Add-in Card how much power the Add-in Card can use during both Initial Power Up and Maximum Permitted Power. In the PCI CEM Gen 5 spec these levels are called “Connector Initial Permitted Power” and “Connector Maximum Permitted Power” because they refer to the power limits that can be consumed through the Auxiliary

Power Connector. The Maximum Permitted Power is the maximum supported by this auxiliary power connector alone. It does not correspond to power consumed through motherboard card edge connector.

The PSU providing the 12VHPWR auxiliary power connector must short the appropriate SENSE signals to ground or leave them open (high impedance) to indicate the power limits associated with the power supply. These SENSE signals must not change state while the Add-in Card is operational.

Support of the SENSE0/SENSE1 sideband signals is required for a PSU. Support for the SENSE0/SENSE1 sideband signals does not rely on any of the other optional sideband signals defined for the 12VHPWR connector.

**Table 3-6: PCI Express\* 12VHPWR Connector Power Limits**

Sense0	Sense1	Initial Permitted Power at System Power Up	Maximum Sustain Power after Software Configuration
Gnd	Gnd	375 W	600 W
Open	Gnd	225 W	450 W
Gnd	Open	150 W	300 W
Open	Open	100 W	150 W

**Note:** If the Add-In-Card does not monitor these signals, it must default to the lowest value in this table.

### 3.3.2 CARD\_PWR\_STABLE (Optional)

This optional sideband signal functions as a “Power Good” indicator from the Add-in Card to the PSU. When this signal is asserted, the Add-in Card is indicating that local power rails on the Add-in Card are within their operating limits. This signal can provide a fault detection from the Add-in Cards to the PSU, which can allow the PSU a protection opportunity.

If this signal is used by the PSU, the signal will come from the Add-in Card as an open collector / open-drain fashion. In the Add-in Card, this signal will be tied to a 100kΩ pull-down resistor to ground. When implemented, the signal must be tied to a 4.7kΩ pull-up resistor to +3.3V at the power supply. When the PSU or system monitors the state of the CARD\_PWR\_STABLE signal it must be done with a high impedance 3.3V logic compatible device input.

The Add-in Card will set this signal to Open (high impedance) whenever its local power rails that are critical to correct operation are within their operating limits. When the Add-in Card directly drives this signal low (0 / Ground), any of its local power rails are outside of their operating limits results in a fault for the Add-in Card. The Add-in Cards must drive this signal low for at least 100 ms or as long as the input power stays outside of the voltage specification detailed in [Table 3-5](#) in Section [3.2](#) of this document. When the voltage returns to within correct operating ranges and the fault is done, the signal will change to open (high impedance).

Support for this optional sideband signal does not rely on any of the other sideband signals defined for the 12VHPWR connector and can be implemented independently of other of these sideband signals.

### 3.3.3 CARD\_CBL\_PRES# (Optional)

This sideband signal has two functions:

- Primary Function:
  - This sideband signal provides a signal from the Add-in Card to the PSU that an Add-in Card has been detected and is correctly attached to the 12VHPWR Auxiliary Power Connector.
  - The primary function is required for all PCIe\* Gen 5.0 Add-in Cards.
- Secondary Function:
  - This sideband signal provides communication from the Add-in Card to tell the PSU when an Add-in Card is present and can be included in the "Power Budgeting Sense Detect Registers". This allows the system to correlate which system and power cables are used with specific PCIe\* card slot.

**Note:** This sideband signal is for the purpose of the system power supply management support. It is not for the purpose of the Add-in Card to determine the power limits available to it. Power limits to the Add-in Card are communicated by the SENSE0/SENSE1 signals.

The CARD\_CBL\_PRES# signal is tied to a 4.7kΩ pull-down resistor to ground on the Add-in Cards. This signal is required for all PCIe\* Gen 5.0 Add-in Cards, it will traverse the sideband signals of the 12VHPWR connector. If the PSU monitors the state of the CARD\_CBL\_PRES# signal, it must do so with a high impedance 3.3V logic compatible device input. This signal will be low at the Add-in Cards at all times when main power is absent. For a PSU to detect the active low presence condition of the CARD\_CBL\_PRES# signal a 100kΩ pull-up resistor to 3.3V is required.

When supporting the secondary function, the Add-in Card reads this signal on a high impedance 3.3V logic compatible input and record the logic high/low state in the "Power Budgeting Sense Detect" registers. The PSU is allowed to drive this signal high with a push-pull driver to 3.3V.

Support for this optional sideband signal does not rely on any of the other sideband signals defined for the 12VHPWR connector and can be implemented independently of other of these sideband signals.

For a power supply this sideband signal can be used to determine how many PCIe\* Add-in Cards are connected to the power supply. Then the power supply could determine how much power it can provide to each 12VHPWR connector via the SENSE0/1 sideband signals. If this feature is used, and the SENSE0/1 signals are dynamically changed, they must be changed only when the power supply is in Standby Mode (PS\_ON# is de-asserted and Main Power rails are not on). Once PS\_ON# and the main power rails achieve their full voltages the SENSE0/1 sideband signals must not be changed.

An example for this scenario would be if a power supply has enough rated power to supply 600 Watts to one PCIe\* Add-in Card it could determine the following scenarios:

- One PCIe\* Add-in Card is detected, and that one card gets 600 Watt.

- Two PCIe\* Add-in Cards are detected, each card gets 300 Watts.
- Three or Four PCIe\* Add-in Cards are detected, each card gets 150 Watts.

### 3.3.4 Sideband Signals DC Specifications (Required)

The four sideband signals defined for the 12VHPWR connector DC Specifications are shown in [Table 3-7](#). This is the requirement defined by the PCIe\* CEM 5 Specification for the Add-In-Cards.

**Table 3-7: PCI Express\* 12VHPWR Connector – Sideband Signal DC Specifications**

Symbol	Parameter	Conditions	Min	Max
VHMAX	Max High Voltage any Pin			3.3 V +0.5 V
VIL	Input Low Voltage		-0.2 V	+0.8 V
VIH	Input High Voltage		+2.0 V	3.3 V +0.2 V
VOL	Output Low Voltage	7.0 mA	-0.2 V	+0.5 V
VOH	Output High Voltage (see note)	4.0 mA	+2.4 V	3.3 V + 0.2 V
RPULL-UP	Pull-up / Pull-down Resistance tolerance		-10%	+10%

**Note:** For Open-Collector/Open Drain Signal CARD\_PWR\_STABLE output a pull-up is required. There is no VOH specification for this signal.



## 4 Electrical

The following electrical requirements are required and must be met over the environmental ranges as defined in Chapter 2 (unless otherwise noted).

### 4.1 AC Input – REQUIRED

Table 4-1 lists AC input voltage and frequency requirements for continuous operation. The power supply shall be capable of supplying full-rated output power over two input voltage ranges rated 90-135 VAC and 180-265 VAC rms nominal. The correct input range for use in a given environment may be either switch-selectable or auto-ranging. The power supply shall automatically recover from AC power loss. The power supply must be able to start up under full loading at 90 VAC.

**Note:** [OPTIONAL] 115 VAC or 230 VAC only power supplies are an option for specific geographical or other requirements.

**Table 4-1: AC Input Line Requirements**

Parameter	Minimum	Nominal <sup>1</sup>	Maximum	Unit
V <sub>in</sub> (115 VAC)	90	115	135	VAC <sub>rms</sub>
V <sub>in</sub> (230VAC)	180	230	265	VAC <sub>rms</sub>
V <sub>in</sub> Frequency	47	-	63	Hz

**NOTE:**

- Nominal voltages for test purposes are to be within  $\pm 1.0V$  of nominal.

#### 4.1.1 Input Over Current Protection (Required)

The power supply is required to incorporate primary fusing for input over current protection to prevent damage to the power supply and meet product safety requirements. Fuses should be slow-blow-type or equivalent to prevent nuisance trips.

#### 4.1.2 Inrush Current (Required)

Maximum inrush current from power-on (with power-on at any point on the AC sine) and including, but not limited to, three line cycles, shall be limited to a level below the surge rating of the AC switch if present, bridge rectifier, and fuse components. Repetitive ON/OFF cycling of the AC input voltage must not damage the power supply or cause the input fuse to blow.

#### 4.1.3 Input Under Voltage (Required)

The power supply is required to contain protection circuitry such that the application of an input voltage below the minimum specified in the Table 4-1, must not cause damage to the power supply.

## 4.2 DC Output (Required)

The Single Rail Desktop Power Supply will use +12V for all main power to the computer with a +12VSB that will be used in Sleep, ALPM, or Off type modes. The +12V power can be split into multiple 12V rails to comply with 240VA safety requirements or be one large 12V rail depending on power supply and system manufacturing needs.

### 4.2.1 DC Voltage Regulation (Required)

The DC output voltages are required to remain within the regulation ranges shown in the Table 4-2, when measured at the load end of the output connectors under all line, load, and environmental conditions specified in Chapter 7.

The lower voltage range for +12V is allowed to be -7% to allow for the power excursion requirements now described in Section 3.1. To compensate for these power excursions the nominal voltage could be changed to 12.1 or 12.2 Volts, depending on Power Supply design.

**Table 4-2: DC Output Voltage Regulation**

Output	Range	Min	Nominal	Max	Unit
+12V1DC <sup>1</sup>	+5% / -7%	+11.20	+12.00	+12.60	V
+12V2DC <sup>2</sup>	+5% / -7%	+11.20	+12.00	+12.60	V
+12VSB	+5% / -7%	+11.20	+12.00	+12.60	V

**NOTES:**

1. Voltage tolerance is required at all connectors

### 4.2.2 DC Output Current (Required)

The below table summarizes the expected output transient step sizes for each output. All items in the below table are REQUIRED, unless specifically called out as RECOMMENDED.

**Table 4-3: DC Output Transient Step Sizes**

Output	Maximum Step Size (% of Rated Output Amps)	Maximum Step Size (A)
+12V1DC <sup>4</sup>	40% (Required) 70% (Recommended)	-
+12V2DC <sup>4</sup>	85% of CPU supported in Table 2-1 <sup>1</sup>	-
+12V3/4 <sup>4</sup>	Steps from 100% → 300% <sup>3</sup> 30% → 100% <sup>2</sup>	
+12VSB	-	0.5

**NOTES:**

1. 12V2 rails are typically used for CPU power. CPU step size will have more updated values in the Power Supply Design Guide Addendum (# 621484) which will be used to determine the 85% value
2. 12V3/V4 rails are typically used for PCIe\* Add-in Card connectors. This recommendation is based on Section 3 where PCIe\* Add-in Card needs are discussed. The step size will come from the amount of PCIe\* Add-in Card power supported based on the size of the PSU in [Table 3-2](#). For more detail reference the Desktop Platform Form Factor Power Supply Test Plan (Doc # [338448](#))
3. If a power supply has multiple 12VHPWR connectors, Dynamic testing shall be done on each 12VHPWR connector. For more detail reference the *Desktop Platform Form Factor Power Supply Test Plan* (Doc # [338448](#))
4. Power supplies that have one combined 12V rail shall perform Dynamic testing on the one 12V rail with multiple tests which simulate different system level workloads: 12V1 (total system), 12V2 (CPU Load), and 12V3/V4 (PCIe\* AIC).

Output voltages should remain within the regulation limits of [Table 4-2](#), for instantaneous changes in load as specified in [Table 4-3](#) and for the following conditions:

- Simultaneous load steps on the +12 VDC output (all steps occurring in the same direction)
- Load-changing repetition rate of 50 Hz to 10 kHz
- AC input range as per Section [2.1](#) and Capacitive loading per [Table 4-7](#).

The transient load slew rate is defined in the [Table 4-4](#) based on PSU supporting any PCIe\* Auxiliary Power Connectors. This usually can be correlated to the PSU’s Rated Wattage, which is listed as a guidance.

**Table 4-4: DC Output Transient Slew Rate**

Output	PSU without PCIe* 12VHPWR Connectors (Recommended Size ≤450 Watts)	PSU with PCIe* 12VHPWR Connector (Recommended Size >450 Watts)
All +12V	2.5 A/μS	5.0 A/μS
+12VSB	0.1 A/μS	0.1 A/μS

### 4.2.3 Remote Sensing (Optional)

Remote sensing is optional. Remote sensing can accurately control motherboard loads by adding it to the PSU connector. This is for the power supply to monitor the 12V Voltage to the motherboard connector, through remote sensing, and then compensate the voltage if there is excessive cable Voltage drop. The default sense should be connected to pin 10 of the main power connector. The power supply should draw no more than 10 mA through the remote sense line to keep DC offset voltages to a minimum.

### 4.2.4 Other Low Power System Requirements (Required)

To help meet multiple world-wide Energy Regulations the +5VSB standby rail must meet the following efficiency as shown in Table 4-5 which is measured with the main outputs off (PS\_ON# high state). These World-Wide Energy Regulations and standards

include: Blue Angel\* system requirements, RAL-UZ 78, US Presidential executive order 13221, ENERGY STAR\*, ErP Lot 6 requirements (2010 and 2013 levels), and 2014 ErP Lot 3 requirements. Additionally, if any Computers use an Alternative Low Power Mode (ALPM) then the +5VSB standby efficiency has similar requirements as shown below.

**Table 4-5: Required System DC and AC Power Consumption**

12VSB Load Target	12VSB Actual Load	Efficiency Target (Both 115V and 230V Input)	Remark
Max / Label	1.5 A / Label	75%	Recommend
0.625 A		75%	REQUIRED ALPM and ErP Lot 3 2014
400 mA		75%	Recommend
230 mA		75%	REQUIRED ALPM and ErP* Lot 3 2014
38 mA		55%	Recommend
19 mA		45%	REQUIRED ErP* Lot 6 2013

### 4.2.5 Output Ripple Noise (Required)

The output ripple and noise requirements listed in the Table 4-6 must be met throughout the load ranges specified for the appropriate form factor and under all input voltage conditions as specified in [Table 4-1](#).

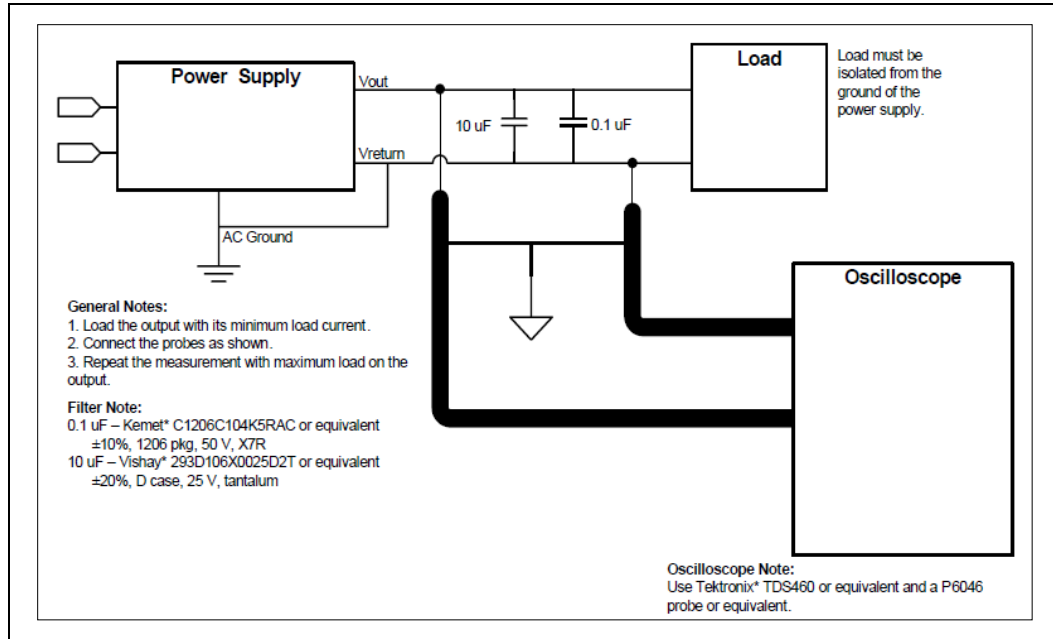
Ripple and noise are defined as periodic or random signals over a frequency band of 10 Hz to 20 MHz. Measurements must be made with an oscilloscope with 20 MHz of bandwidth. Outputs should be bypassed at the connector with a 0.1µF ceramic disk capacitor and a 10 µF electrolytic capacitor to simulate system loading. Refer to Figure 4-1 for the differential noise measurement setup.

**Table 4-6: DC Output Noise/Ripple**

Output	Maximum Ripple and Noise (mV p-p)
+12V1DC	120
+12V2DC	120
+12VSB	120



**Figure 4-1: Differential Noise Test Setup**



### 4.2.6 Capacitive Load (Recommended)

The power supply should be able to power up and operate within the regulation limits defined in [Table 4-2](#), with the following capacitances simultaneously present on the DC outputs. These Capacitive Loads are to simulate what a motherboard / system provides when connected to a power supply.

**Table 4-7: Output Capacitive Loads**

Output	Capacitive Load (µF)
+12V1DC	3,300
+12V2DC	3,300
+12VSB	3,300

### 4.2.7 Closed Loop Stability (Required)

The power supply shall be unconditionally stable under all line/load/transient load conditions including capacitive loads specified in Section [4.2.6](#). A minimum of 45 degrees phase margin and 10 dB gain margin is recommended at both the maximum and minimum loads.

### 4.2.8 Multiple 12V Rail Power Sequencing (Required)

If the power supply has multiple +12VDC rails all output rails must reach its minimum in-regulation level (11.2V) within 20ms of when the first +12VDC rail reaches its minimum in-regulation level (11.2V).

### 4.2.9 Voltage Hold-Up Time (Required)

The power supply shall maintain output regulations per [Table 4-2](#) despite a loss of input power at the low-end nominal range-115 VAC / 47 Hz or 230 VAC / 47 Hz – at maximum continuous output load as applicable for a minimum of 17 ms (T5+T6).

## 4.3 Timing, Housekeeping, and Control (Required)

Figure 4-2: Power on Timing

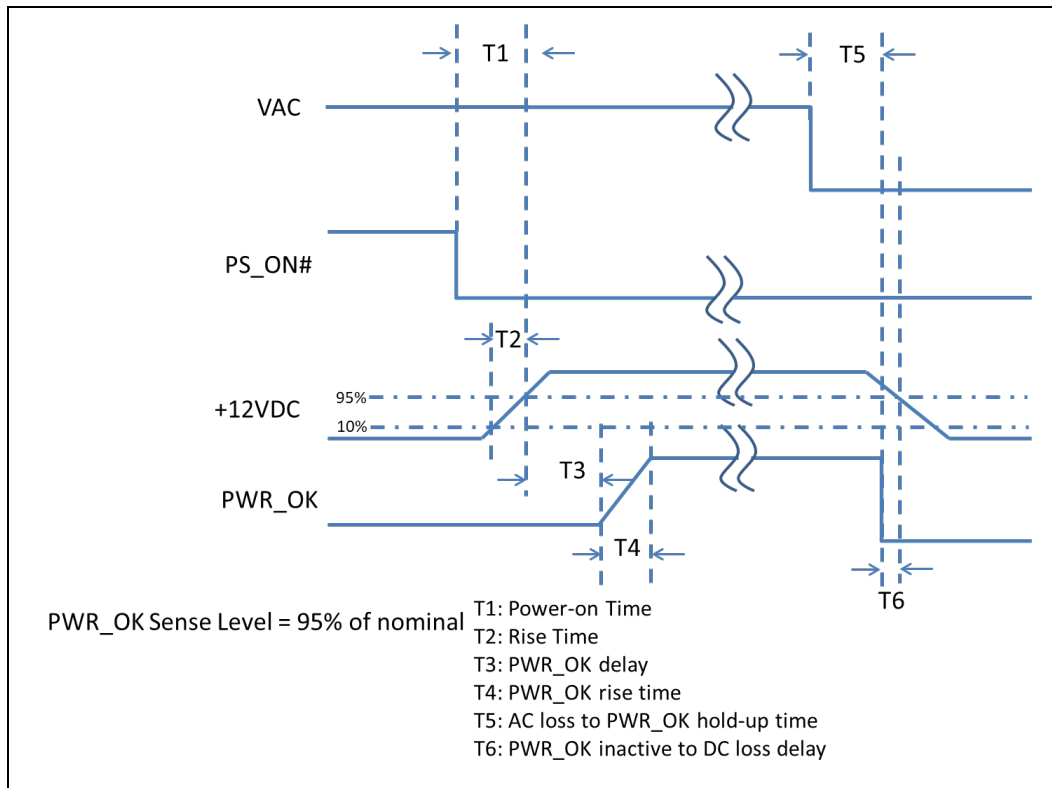


Table 4-8: Power Supply Timing

Parameter	Description	Value	
		Required	Recommended
T0	AC power on time <sup>4</sup>	<2s	
T1	Power-on time <sup>3</sup>	<150ms <sup>1</sup>	<100 ms

Parameter	Description	Value	
		Required	Recommended
T2	Rise time	0.2–20 ms	
T3	PWR_OK delay <sup>3</sup>	1ms – 150ms <sup>4</sup>	1–100 ms
T4	PWR_OK rise time	< 10 ms	
T5	AC loss to PWR_OK hold-up time <sup>3</sup>	> 16 ms <sup>2</sup>	
T6	PWR_OK inactive to DC loss delay	> 1 ms	

**NOTES:**

1. T1 and T3 required values are set to meet timing requirement for computers that use ALPM.
2. T5 to be defined for both max/min load condition.
3. PSUs are recommended to label or indicate the timing value for system designer and integrator reference for T1 and T3. This allows system designers to optimize “turn on” time within the system.
4. T0 is shown in Section [4.3.3](#), [Figure 4-4](#).

### 4.3.1 PWR\_OK (Required)

PWR\_OK is a “power good” signal. This signal shall be asserted high by the power supply to indicate that the +12 VDC outputs are within the regulation thresholds listed in [Table 4-2](#) and that sufficient mains energy is stored by the converter to guarantee continuous power operation within the specification for at least the duration specified in Section [4.2.9](#). Conversely, PWR\_OK shall be de-asserted to a low state when any of the +12 VDC output voltages fall below its voltage threshold, or when mains power has been removed for a time sufficiently long enough, such that power supply operation cannot be guaranteed. The electrical and timing characteristics of the PWR\_OK signal is given in the below table.

**Table 4-9: PWR\_OK Signal Characteristics**

<b>Signal Type</b>	+5 V TTL compatible
<b>Logic level Low</b>	< 0.4 V while sinking 4 mA
<b>Logic level High</b>	Between 2.4 V and 5 V output while sourcing 200 $\mu$ A
<b>High State Output Impedance</b>	1 k $\Omega$ from output to common
<b>Max Ripple/Noise</b>	400 mV p-p

### 4.3.2 PS\_ON# (Required)

PS\_ON# is an active-low, TTL-compatible signal that allows a motherboard to remotely control the power supply in conjunction with features such as soft on/off, Wake on LAN, or wake-on-modem. When PS\_ON# is pulled to TTL low, the power supply shall turn on the main DC output rail: +12 VDC. When PS\_ON# is pulled to TTL high or open-circuited, the DC output rails should not deliver current and should be

held at zero potential with respect to ground. PS\_ON# has no effect on the +12VSB output, which is always enabled whenever the AC power is present. To support systems with ALPM this is required for all power supplies. The power supply may be asked to turn back on before all voltage rails have turned off. The power supply must be able to turn back on via a change in the PS\_ON# signal after 100 ms of the PS\_ON# signal being de-asserted. The power supply shall not latch into a shutdown state when PS\_ON# is driven active by pulses between 10 ms to 100 ms during the decay of the power rails. When PS\_ON# de-asserts (turn on the PSU) with a time that is greater than 100 ms, from when it is first asserted (turns off), the PSU must respond to this request and turn back on all voltages rails no matter where the voltage rails are in ramping down the voltage to an Off state.

Table 4-10 lists PS\_ON# signal characteristics.

The power supply shall provide an internal pull-up to TTL high. The power supply shall also provide debounce circuitry on PS\_ON# to prevent it from oscillating on/off at startup when activated by a mechanical switch. The DC output enable circuitry must be SELV-compliant in case a human touches the PS\_ON# pin.

The power supply shall not latch into a shutdown state when PS\_ON# is driven active by pulses between 10 ms to 100 ms during the decay of the power rails. When PS\_ON# de-asserts (turn on the PSU) with a time that is greater than 100 ms, from when it is first asserted (turns off), the PSU must respond to this request and turn back on all voltages rails no matter where the voltage rails are in ramping down the voltage to an Off state.

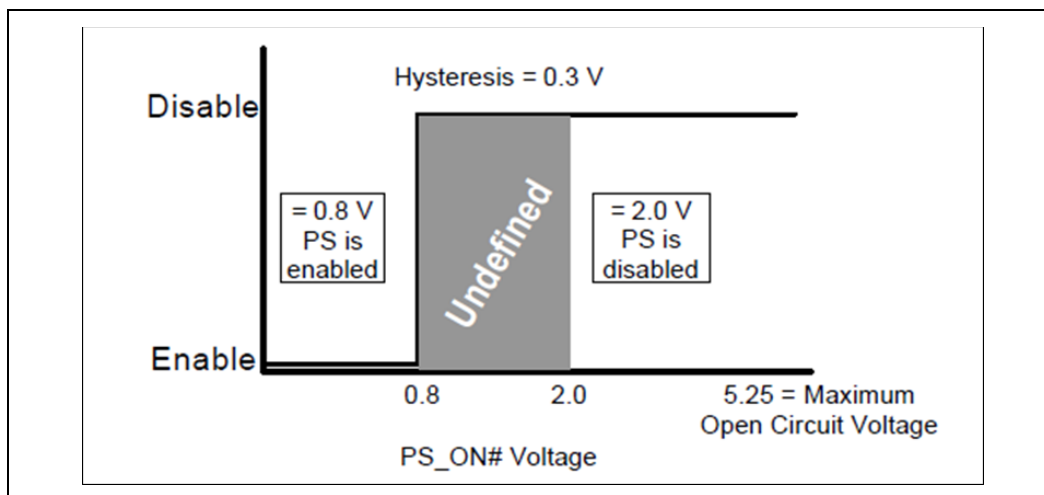
**Table 4-10: PS\_ON# Signal Characteristics**

Parameter	Minimum	Maximum
V <sub>IL</sub>	0	0.8 V
I <sub>IL</sub> (V <sub>IN</sub> = 0.4 V)	-	-1.6 mA <sup>1</sup>
V <sub>IH</sub> (I <sub>IN</sub> = 200 uA)	2.0 V	-
V <sub>IH</sub> open circuit	-	-5.25 V
Ripple / Noise		400 mV p-p

**NOTES:**

1. Negative current indicates that the current is flowing from the power supply to the motherboard.
2. Due to PS\_ON# toggle on/off frequently, system and PSU component's reliability should be considered based on the days, months, or years of claimed warranty listed on product specification. Refer to Section [10.2](#) for more details about PSU design consideration for S0ix mode.

Figure 4-3: PS\_ON# Signal Characteristics



### 4.3.3 +12VSB (Required)

+12VSB is a standby supply output that is active whenever the AC power is present. This output provides a power source for circuits that must remain operational when the main 12V DC output rails are in a disabled state. Example uses include soft power control, Wake on LAN, wake-on-modem, intrusion detection, Alternative Low Power Modes (ALPM) or suspend state activities.

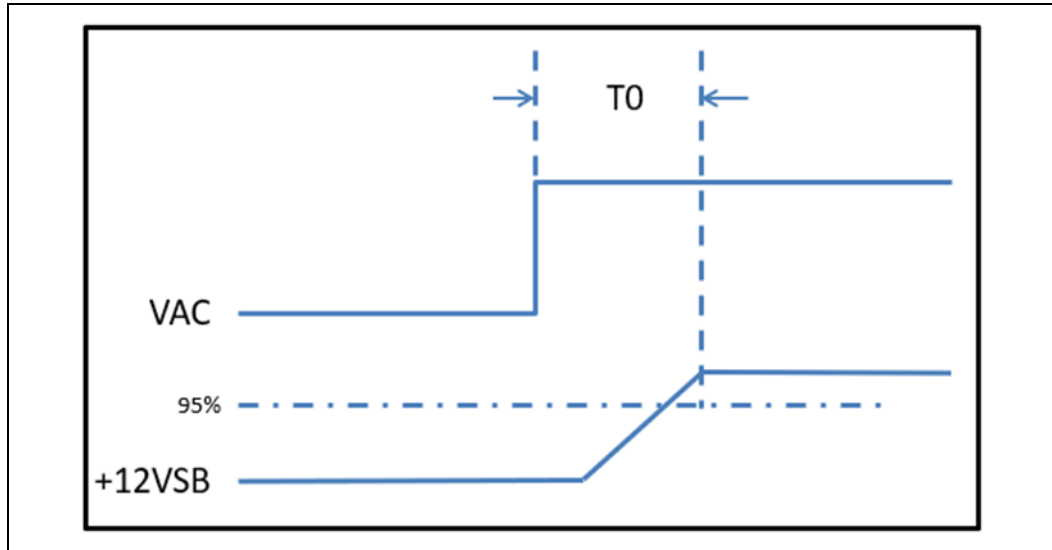
The power supply must be able to provide the required power during a "wake up" event. If an external USB device generates the event, there may be peak currents around 2.0 A or higher, lasting no more than 500 ms.

Over current protection is required on the +12VSB output regardless of the output current rating. This ensures the power supply will not be damaged if external circuits draw more current than the supply can provide.

With new modes of operation for computers like Alternative Low Power Modes (ALPM) the continuous current rating of the 12VSB rail is recommended to be at least 1.5 A (18 Watts). Some scenarios like USB Power Charging in Sleep or ALPM could require more current on the 12VSB rail like 2.0 Amps or more depending on the design.

It is recommended that power supplies with a size of 1200 watts or larger to have the 12VSB Rail of at least 3.0 Amps to support larger memory sizes with larger power systems.

Figure 4-4: +12VSB Power on Timing versus VAC



#### 4.3.4 Power-On Time (Required)

The power-on time is defined as the time from when PS\_ON# is pulled low to when the +12 VDC output is within the regulation ranges specified in [Table 4-2](#). The power-on time shall be less than 150 ms ( $T1 < 150$  ms).

+12VSB shall have a power-on time of two second maximum after application of valid AC voltages as shown in the above figure. The 12VSB power on time is T0 as listed in Section [4.3.3](#).

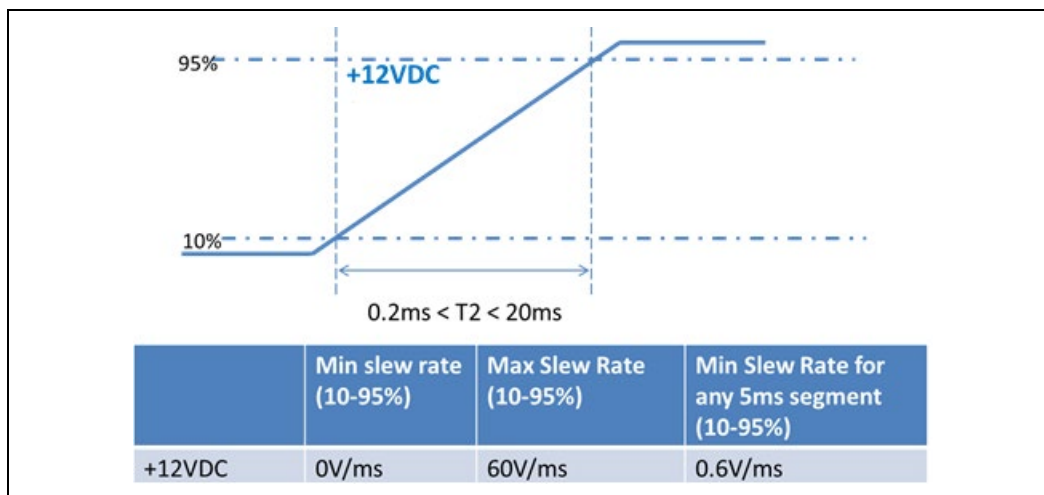
#### 4.3.5 Rise Time (Required)

The output voltages shall rise from 10% of nominal to within the regulation ranges specified in [Table 4-2](#) within 0.2 ms to 20 ms ( $0.2 \text{ ms} \leq T2 \leq 20 \text{ ms}$ ). The total time for Rise time of each voltage is listed in [Table 4-8](#): Power Supply Timing as T2.

There must be a smooth and continuous ramp of each DC output voltage from 10% to 95% of its final set point within the regulation band, while loaded as specified.

The smooth turn-on requires that, during the 10% to 95% portion of the rise time, the slope of the turn-on waveform must be positive and have a value of between 0 V/ms and  $[V_{out, \text{nominal}} / 0.2]$  V/ms. Also, for any 5 ms segment of the 10% to 95% rise time waveform, a straight line drawn between the endpoints of the waveform segment must have a slope  $\geq [V_{out, \text{nominal}} / 20]$  V/ms.

Figure 4-5: Rise Time Characteristics



### 4.3.6 Overshoot at Turn-On / Turn-Off (Required)

The output voltage overshoot upon the application or removal of the input voltage, or the assertion/de-assertion of PS\_ON#, under the conditions specified in [Table 4-2](#), shall be less than 10% above the nominal voltage. No voltage of opposite polarity shall be present on any output during turn-on or turn-off.

### 4.3.7 I\_PSU% Signal (Required)

I\_PSU% is a signal coming from the power supply that reports the proportionality of Power being delivered by the +12VDC rail with the Output-Load rating of the PSU. Which is represented as a unitless percentage of the total capacity using a current mode. If multiple +12VDC rails are implemented (for example, +12V1DC, +12V2DC) then I\_PSU% must report the utilization ratio of the combined total capacity.

Table 4-11: I\_PSU% Signal Characteristics

Parameter	Description
Sensitivity	10 μA per 1% of capacity 1.0mA @ 100% of capacity 2.0mA @ 200% of capacity Examples: 750W, 61A = 10uA /.61A 600W, 50A = 10uA/.5A
Maximum Reporting Capability	200% <sup>1</sup>
Operational voltage range	0 - 3.3V
RL and CL Time Constant & Sample Values	RC Time Constant Value = 924 ns = RL * CL (± 10%, Error margin for RC Time Constant is large due to variance in standard resistor and capacitor values that would make up this time constant value.)

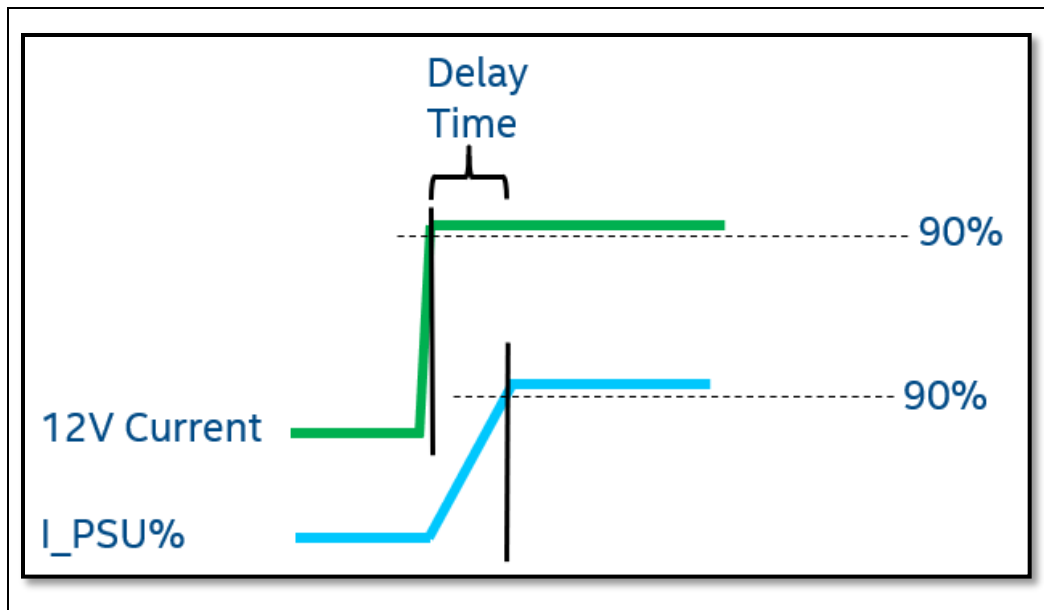
Parameter	Description
	RL_low = 511 Ohms 1% for 1V @ 200% loading CL_low = 1800pF, 5% for 1V @ 200% loading  RL_high = 1.65K ohm 1% for 3.3V @200% loading CL_high = 560 pF, 5% for 3.3V @200% loading
Accuracy I_PSU%	≤5% @ 121% to 200% of Rated Power ≤2.5% @ 80% to 120% of Rated Power ≤10% @ 40% to 79% of Rated Power ≤20% @ 20% to 39% of Rated Power Accuracy needs to be tuned to be best @ 100% load.
I_PSU% Delay Time	<100 uSec (Required) <60 uSec (Recommended) Testing Condition: step size is from 30% of rated power to 120% of rated power, See Figure 4-6
I_PSU% Ripple/Noise	Measured @ 100% load, Required <10% of full-scale voltage Recommended <7% of full-scale voltage

**Note:** The Spec allows that based on current mode reporting 200% of the power supplies rated capacity is possible for the system to read. There is not a requirement for the power supply to deliver up to 200% of rated capacity outside of Power Excursion requirements. Refer to [Table 4-12](#) for peak power requirements.

I\_PSU% Delay time is defined as the amount of time between when a current change happens and when the I\_PSU% signal from the PSU reports that change to the system. This Delay time is measured when the current change reaches the 90% level of the new current value to when the I\_PSU% signal reaches 90% level reporting the % of total output. Testing needs to happen with the DC Load Slew Rate set to at least 5A/uS. Test condition is when the current increases from 30% to 120% of the rated PSU size. This is similar to the DC Output Transient Step size in [Table 4-3](#). During testing of all I\_PSU% testing conditions (Accuracy, Delay Time, and Ripple/Noise) the capacitive load described in [Table 4-7](#) is applied to these tests.



Figure 4-6: I\_PSU% Delay Time Diagram



Inside the power supply, a transconductance amplifier needs to be added to report the I\_PSU% signal. [Figure 4-7](#) below is a reference schematic for the circuitry that needs to be included. The green box represents the power supply. For the transconductance amplifier the Iout equation of I\_PSU% is shown here:

$$I_o = \frac{R_f}{R_i * R_{ref}} v_i$$

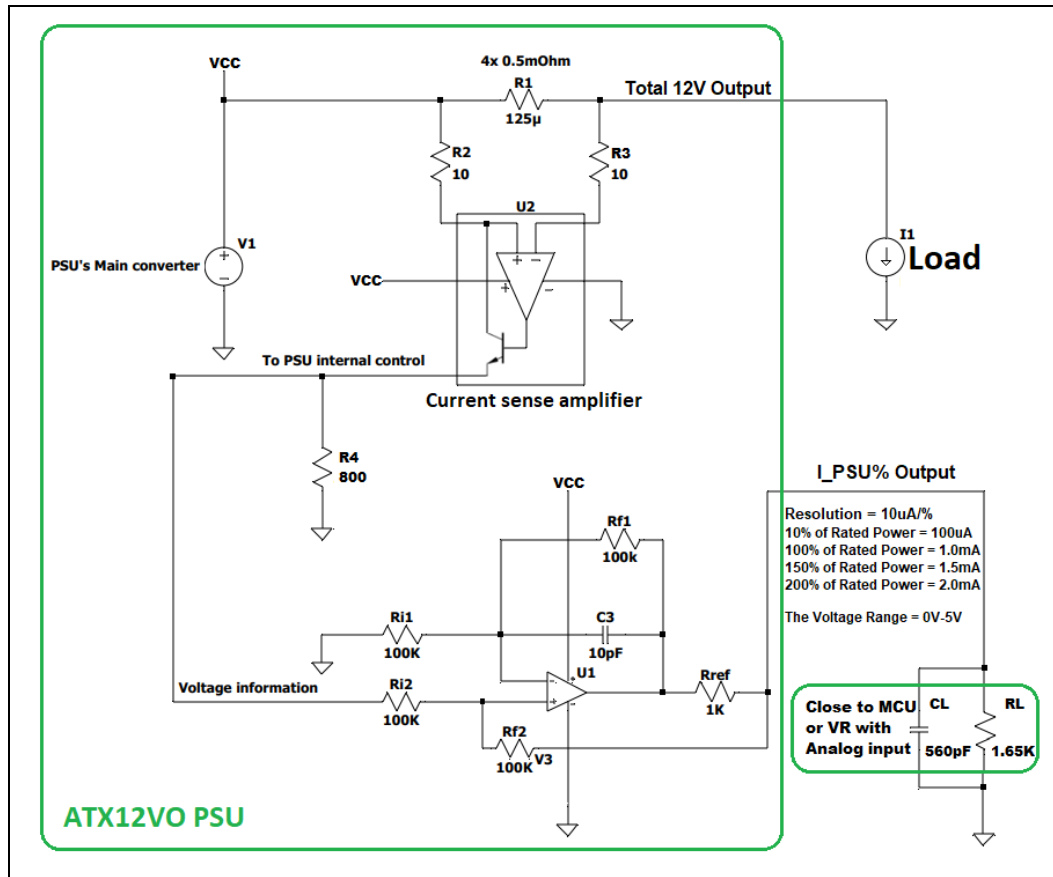
The Figure shows the Total 12V Main output that represents all power connectors to the system. The diagram is simplified to show all load with just I1.

The I\_PSU% signal is routed to the Psys pin on the CPU's IMVP controller on the motherboard. Also, on the motherboard is RL and CL, which are in parallel with each other and placed as close to the IMVP controller as possible. [Table 4-11](#) shows the range of values that RL and CL should be. Capacitor recommendation is COG (NPO) type. Resistors are recommended to be 1% type and capacitor are recommended to be 5% type.

For all Accuracy, Delay Time and Ripple/Noise measurements, testing is to be completed with both the RL\_low + CL\_low and RL\_high + CL\_high combinations.

When calculating the value for C3 the I\_PSU% Delay time requirements need to be considered.

Figure 4-7: Recommended Circuit Diagram for I\_PSU% signal inside PSU



#### 4.3.7.1 PCIe\* CEM Gen 5 Power Excursions and I\_PSU% (Required)

Section 3.1 of this document details peak power requirements for a power supply. When a power supply includes I\_PSU%, the peak power requirements are less for all time criteria except the short time and highest level. This reduction in peak power requirements creates a significant benefit to use the I\_PSU% feature in a desktop system. This is because the power supply is reporting the system consumption back to the system and the power management control of the processor can react to it quickly. Based on the power budgets in Table 3-2 and peak power of both the Processor detailed in Table 2-1 and the PCIe\* Add-In-Card in Section 3.1, the following Peak Power Requirements are defined for a Power Supply that includes I\_PSU%. These Peak Power requirements are different based on its rated output power and inclusion of the 12VHPWR connector to lower the impact of these peak power requirements in smaller power supplies or power supplies without the 12VHPWR connector. The PCIe\* Power Excursions defined in Section 3.1 will have the biggest impact on a power supply when it includes a 12VHPWR connector. See Table 4-12 for details.

**Table 4-12: PCIE AIC and PSU Power Budget used for Peak Power Excursion**

Power Excursion as a % of PSU Size			Time for Power Excursion (TE)	Testing Duty Cycle
≤450 watts or any PSU without a 12VHPWR connector	450 Watts < PSU < 1000 watts	≥1000 watts		
150%	200%	200%	110 us	5%
130%	130%	150%	1 ms	8%
120%	120%	120%	10 ms	12.5%
110%	110%	110%	100 ms	25%
100%	100%	100%	Infinite	--

The 200% Peak Power Excursion time increases compare to what is listed in [Table 3-3](#) to include the time it takes for I\_PSU% to report that the power supply is above 100% plus the time it takes for the processor to react to that level of power excursion.

The Testing Duty Cycle is the same as defined in [Section 3.1.2](#), which is needed to test a specific power supply.

The Test Criteria for these peak power excursions are different than what was specified in [Section 3.1.2](#). When a PSU includes I\_PSU%, [Table 4-13](#) and [Table 4-14](#) show the RMS test conditions based on the power excursions defined. For all power supplies with a rated wattage different than the two examples shown will require a similar RMS calculation to be performed.

**Table 4-13: Duty Cycle Example Test Criteria for a 750W PSU – RMS**

Duty Cycle	Time Constant (TC)	Time for Power Excursion (TE)	Power @ TC	Power @ TE
5%	1890 μs	110 μs	688.2 W	1500 W
8%	11.5 ms	1 ms	727.2 W	975 W
12.5%	70 ms	10 ms	726 W	900 W
25%	300 ms	100 ms	723 W	825 W

**Table 4-14: Duty Cycle Example Test Criteria for a 1000W PSU – RMS**

Duty Cycle	Time Constant (TC)	Time for Power Excursion (TE)	Power @ TC	Power @ TE
5%	1890 μs	110μS	917.7 W	2000w
8%	11.5 ms	1mS	944.1 W	1500w
12.5%	70 ms	10mS	968.1 W	1200w
25%	300 ms	100mS	964.4 W	1100w

**NOTES:**

1. The Capacitive Load mentioned in [Table 4-6](#) is expected to be applied to this test scenario.

2. Total Test time for each Power Excursion testing time is expected to last until thermal saturation occurs in the PSU.
3. More details about test time for each row above and formulas to calculate  $T_C$  and  $T_E$  power values for different PSU sizes will be detailed in the "Desktop Platform Form Factor Power Supply Test Plan - (Doc #[338448](#))

## 4.4 Reset After Shutdown

If the power supply latches into a shutdown state because of a fault condition on its outputs, the power supply returns to normal operation only after the fault has been removed and the PS\_ON# has been cycled OFF/ON with a minimum OFF time of one second.

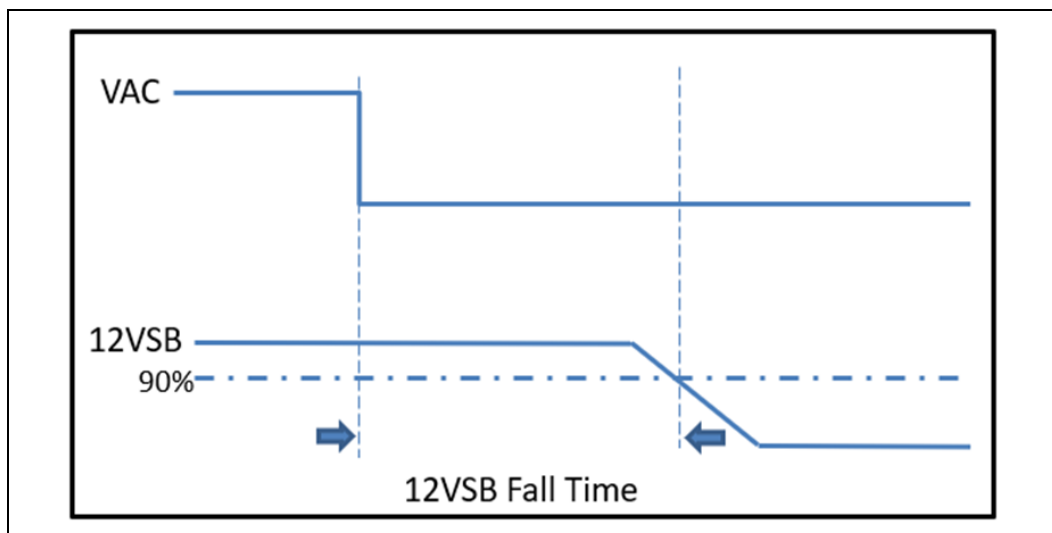
### 4.4.1 +12VSB at Power-Down (Required)

After AC power is removed, the +12VSB standby voltage output shall remain at its steady state value for the minimum hold-up time specified in Section [4.2.9](#) until the output begins to decrease in voltage. The decrease shall be monotonic in nature, dropping to 0.0 V. There shall be no other disturbances of this voltage at or following removal of AC power.

### 4.4.2 +12VSB Fall Time (Recommended)

Power supply 12VSB is recommended to go down to low level within 2 seconds under any load condition after AC power is removed as shown in the below figure. Intel test plan will test at Light 20% Load. If system requires specific +12VSB fall time, the PSU design is recommended to support it.

Figure 4-8: 12VSB Fall Time



## 4.5 Output Protection

### 4.5.1 Over Voltage Protection (OVP) (Required)

The over voltage sense circuitry and reference shall reside in packages that are separate and distinct from the regulator control circuitry and reference. No single point fault shall be able to cause a sustained over voltage condition on any or all outputs. The supply shall provide latch-mode over voltage protection as defined in the below table.

**Table 4-15: Over Voltage Protection**

Output	Minimum (V)	Nominal (V)	Maximum (V)
+12 VDC (Or 12V1DC and 12V2DC)	13.4	15.0	15.6
+12VSB <sup>1</sup>	13.4	15.0	15.6

**NOTE:**

1. Over voltage protection is RECOMMENDED but not REQUIRED for this output. While over voltage protection is not required for this output, system damage may occur in the case of an over voltage event.

### 4.5.2 Short Circuit Protection (SCP) (Required)

An output short circuit is defined as any output impedance of less than 0.1 Ohm. The power supply shall shut down and latch off for shorting +12V DC rails to return. The +12V1 DC and 12V2 DC should have separate short circuit and over current protection. Shorts between main output rails and +12VSB shall not cause any damage to the power supply. The power supply shall either shut down and latch off or fold back for shorting the negative rails. +12VSB must be capable of being shorted indefinitely. When the short is removed, it is recommended that the power supply shall recover automatically or by cycling PS\_ON#. Optionally, the power supply may latch off when a +12VSB short circuit event occurs. The power supply should withstand a continuous short circuit to the output without damage or overstress to the unit (for example, to components, PCB traces, and connectors) under the input conditions specified in [Table 4-1](#).

### 4.5.3 No-Load Situation (Required)

No damage or hazardous condition shall occur with all the DC output connectors disconnected from the load. The power supply may latch into the shutdown state.

### 4.5.4 Over Current Protection (OCP) (Required)

Current protection shall be designed to limit the current to operate within safe operating conditions.

Over current protection schemes, where only the voltage output that experiences the over current event is shut off, may be adequate to maintain safe operation of the power supply and the system; however, damage to the motherboard or other system

components may occur. The recommended over current protection scheme is for the power supply to latch into the shutdown state. PSU connectors, cables and all other components should not be melted or damaged prior reaching to the OCP trigger.

#### 4.5.5 Over Temperature Protection (OTP) (Required)

The power supply shall include an over-temperature protection sensor, which can trip and shut down the power supply at a preset temperature point. Such an overheated condition is typically the result of internal current overloading or a cooling fan failure. If the protection circuit is non-latching, then it should have hysteresis built in to avoid intermittent tripping. PSU connectors, cables and all other components should not be melted or damaged prior reaching to the OCP trigger.

#### 4.5.6 Output Bypass (Required)

The output return shall be connected to the power supply chassis and will be connected to the system chassis by the system components.

#### 4.5.7 Separate Current Limit for 12V2 (Optional)

The 12 V rail on the 2x2 power connector should be a separate current limited output to meet the requirements of UL and EN 60950. This only applies if the PSU is trying to meet a 240VA Energy Hazard Safety Requirement.

#### 4.5.8 Overall Power Supply Efficiency Levels

Test the efficiency of the power supply at nominal input voltage of 115 VAC input and 230 VAC input, under the load conditions defined in the *Generalized Test Protocol for Calculating the Energy Efficiency of Internal Ac-Dc and Dc-Dc Power Supplies* document. This document defines how to determine full load criteria based on the label of each rail of the power supply. The loading condition for testing efficiency represents fully loaded systems, typical (50%) loaded systems, and light (20%) loaded systems.

One of the main reasons to move to a Single Rail Desktop Power Supply design is the opportunity to increase overall efficiency. With that the Efficiency requirements are equivalent to 80 Plus Bronze levels with the 80 Plus program. The Efficiency requirements listed below are applicable to AC Input voltage of 115V.

**Table 4-16: Efficiency Load Minimum Requirements**

Loading	Full Load (100%)	Typical Load (50%)	Light Load (20%)
REQUIRED Minimum Efficiency	82%	85%	82%
80 Plus Silver (For Reference in Table 4-17 Only)	85%	88%	85%

**Low Load Efficiency:**

Computers have decreased Idle power greatly since 2005, to where PSU loss is a big concern for overall AC power of a computer in Idle Mode. The lowest DC load for computers at this Idle Mode is determined to be 10 Watts for mainstream computers and could go lower. Computers with PSU larger than 500 Watts are also expected to have more components and therefore the Idle Mode will be at a higher DC Load. A PSU above 500 Watts will use the Low Load Efficiency set at the 2% level.

Low Load Efficiency is another significant advantage for Single Rail Desktop Power Supplies. Therefore, the Low Load Efficiency requirements are aggressive to help computers meet Energy Regulations that require a very low Idle Power.

Low Load Efficiency requirements are based on overall DC power output and the efficiency levels defined in Table 4-16. These values are shown in the below table.

**Table 4-17: Low Load Efficiency Requirements Depending on Overall PSU Size**

DC Output Rating (W)	10W Load			2% Load		
	Recommended	Required (≥80 Plus Silver)	Required (Only Min Eff Req)	Recommended	Required (≥80 Plus Silver)	Required (Only Min Eff Req)
<400	>75%	≥ 70%	≥ 68%	-	-	
400-500	>72%	≥ 70%	≥ 68%	-	-	
>500	-	-	-	>72%	≥ 70%	≥ 68%

The 10 Watt testing load conditions are defined as:

**Table 4-18: 10W Load Condition (Value in Amps for PSU ≤ 500 Watts)**

Load	+12VSB	+12V
10W	0.04 A	0.80 A

### 4.5.9 Power Supply Efficiency for Energy Regulations - ENERGY STAR\* and CEC PC Computers with High Expandability Score (Recommended)

The efficiency of the power supply should be tested at nominal input voltage of 115 VAC input and 230 VAC input, under the load conditions defined in the form factor specific sections, and under the temperature and operating conditions defined in 7. The loading condition for testing efficiency represents fully loaded systems, typical (50%) loaded systems, and light (20%) loaded systems. For systems being sold into the state of California that meet the High Expandability Computer definition (details at the referenced CEC website below) are required to meet the efficiency target list in Table 4-20: CEC PC Computers with High Expandability Computers.

Visit ENERGY STAR\* Computers Ver.8 website for more details:

- [https://www.energystar.gov/products/spec/computers\\_version\\_8\\_0\\_pd](https://www.energystar.gov/products/spec/computers_version_8_0_pd)

Visit CEC\* website for more details:

- <https://www.energy.ca.gov/rules-and-regulations/appliance-efficiency-regulations-title-20> or
- [energycodeace.com/content/reference-ace-t20-tool](http://energycodeace.com/content/reference-ace-t20-tool), then select section “(v) Computers...”

**Note:** Visit ENERGY STAR\* and CEC website for the latest specification update.

**Table 4-19: ENERGY STAR\* Efficiency versus Load**

Loading	Full Load (100%)	Typical Load (50%)	Light Load (20%)	10% Load	PFC @ 50% Load	Remarks
RECOMMENDED Minimum Efficiency	82%	85%	82%	80%	≥0.9	ES v8 for 500 W and below
RECOMMENDED Minimum Efficiency	87%	90%	87%	80%	≥0.9	ES v8 for above 500 W

**Table 4-20: CEC PC Computers with High Expandability Computers<sup>1</sup> - Efficiency versus Load**

Loading	Full Load (100%)	Typical Load (50%)	Light Load (20%)	PFC
REQUIRED Minimum Efficiency for 115V PSU	87%	90%	87%	≥0.9 @ 50% load
REQUIRED Minimum Efficiency for 230V PSU	88%	92%	88%	≥0.9 @ 50% load

<sup>1</sup> Details about High Expandability Computers definition check CEC computer regulation.

The RECOMMENDED minimum efficiency levels shown in [Table 4-19](#) are required for internal power supplies within the ENERGY STAR\* for Computers Version 8.0 specification.





## 5 Mechanical

---

This chapter contains mechanical guidelines that apply to desktop power supplies regardless of mechanical form factor. For mechanical form factor specific design guides, refer to Section [11](#) through Section [15](#).

### 5.1 Labeling and Marking (Recommended)

The following is a non-inclusive list of suggested markings for each power supply unit. Product regulation stipulations for sale into various geographies may impose additional labeling requirements.

**Manufacturer information:** manufacturer's name, part number and lot date code, etc., in human-readable text and/or bar code formats.

**Nominal AC input operating voltages** (100-127 VAC and 200-240 VAC) and current rating certified by all applicable safety agencies.

**DC output voltages and current ratings.**

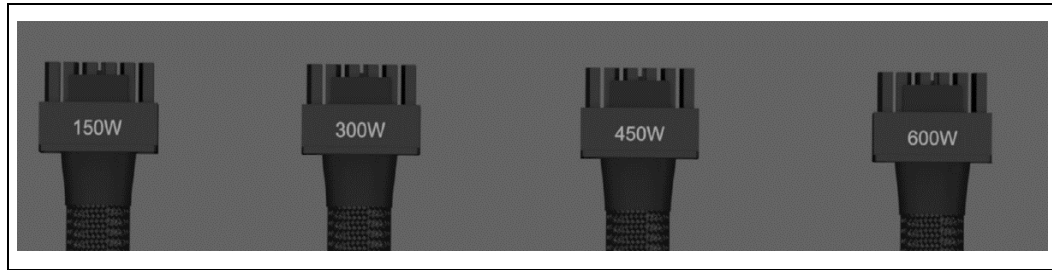
**Revision number of the ATX12VO, SFX12VO, etc. specification** that the power supply meets.

**Access warning text** ("Do not remove this cover. Trained service personnel only. No user serviceable components inside.") must be in English, German, Spanish, French, Chinese, and Japanese with universal warning markings.

Power Supplies are recommended to list if it meets the Recommended Timing values (T1 & T3) in product documentation. There are two levels of timing for T1 and T3 a power supply can support as detailed in [Table 4-8](#). This will help power supplies that meet the lower T1 & T3 timing values highlight that it meets the lower timing values to OEMs and end users.

12VHPWR connector/cable harnesses that are hard-wired to the power supply shall be labeled indicating the **maximum power supported** according to the Sense0/1 encoding implemented for each connector. If PSU is a modular design or if the Sense lines are dynamic (can change in standby mode only), another location on the PSU (highly recommended to be on the PSU Voltage Rail label) and the product documentation must describe the power levels supported. If the criteria for different power levels based on the number of PCIe\* Add-in Cards connected that must be described for the OEM or end user as well. Sense0/1 are described in [Section 3.3.1](#) of this document as illustrated in [Figure 5-1](#) below.

Figure 5-1: 12VHPWR Connector Labeling Example



## 5.2 Connectors (Required)

### 5.2.1 AC Connector

The AC input receptacle shall be an IEC 320 type or equivalent. In lieu of a dedicated switch, the IEC 320 receptacle may be considered the mains disconnect.

### 5.2.2 DC Connectors

The below table shows pinouts and profiles for typical power supply DC harness connectors. The power supply requires an additional two-pin, power connector.

UL Listed or recognized component appliance wiring material rated min 85°C, 300 VDC shall be used for all output wiring.

There are no specific requirements for output wire harness lengths, as these are largely a function of the intended end-use chassis, motherboard, and peripherals. Ideally, wires should be short to minimize electrical/airflow impedance and simplify manufacturing, yet they should be long enough to make all necessary connections without any wire tension (which can cause disconnections during shipping and handling). Minimum harness lengths for general-use power supplies are 150 mm for all wire harnesses. That is very short, and most power supplies need wire harness cables longer than 150mm, consider market conditions and chassis sizes for power supply market wire harness lengths. Measurements are made from the exit port of the power supply case to the wire side of the first connector on the harness.

#### 5.2.2.1 Main Power Connector (Required)

Main Power Connector for motherboard with control and standby rail connections are required. Smaller board sizes can only use this connector.

Table 5-1: 4.2 mm Power Header Main Power Connector Part Numbers

Company	Motherboard Connector Part Number	Cable Connector Part Number
CviLux Corporation*	CP0131013S-HC-NH-X22 (94V-0 black)	CP-01110031-X22 (94V-0 black)
JOINT TECH ELECTRONIC*	C4255WVA-FK-2X05PN0BT1NS3B	C4255HF-2X05PN0BNPNS3G

**Mechanical**

<b>Company</b>	<b>Motherboard Connector Part Number</b>	<b>Cable Connector Part Number</b>
Amphenol*	10157976-1022BPLF	10158000-101LF
Lotes*	GAP-APOW0106-P001A01	ABA-WAF-903-P01
Foxconn*	HMBA050-K3FF2-4H	
Wieson*	AC2211-0009-003-HH	AB9001-0009-005-HH

The mating pilers are unique to this design, refer to figure below. Note connector color can be changed work with connector companies to see what they provide. Motherboard connector color is recommended to be white to show that power into the board is different color than power going out of the board (3 mm SATA Power Connector), which is recommended to be black.

This connector may be provided by other connector companies beyond what is listed above. Contact the preferred connector provider for details. Below is the key for this connector, from motherboard connector view. 18 AWG is recommended for all wires. Connector needs to support 8 amps per pin.

**Figure 5-2: 4.2 mm Power Header 10 pin Main Power - Pin Locations**

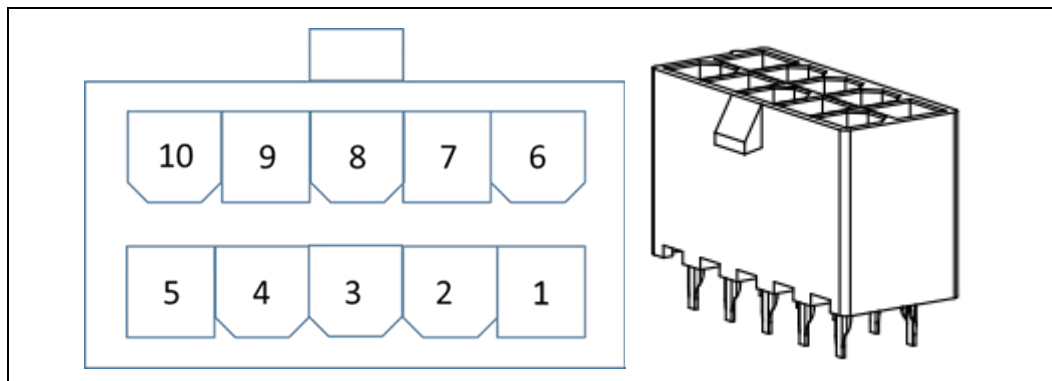
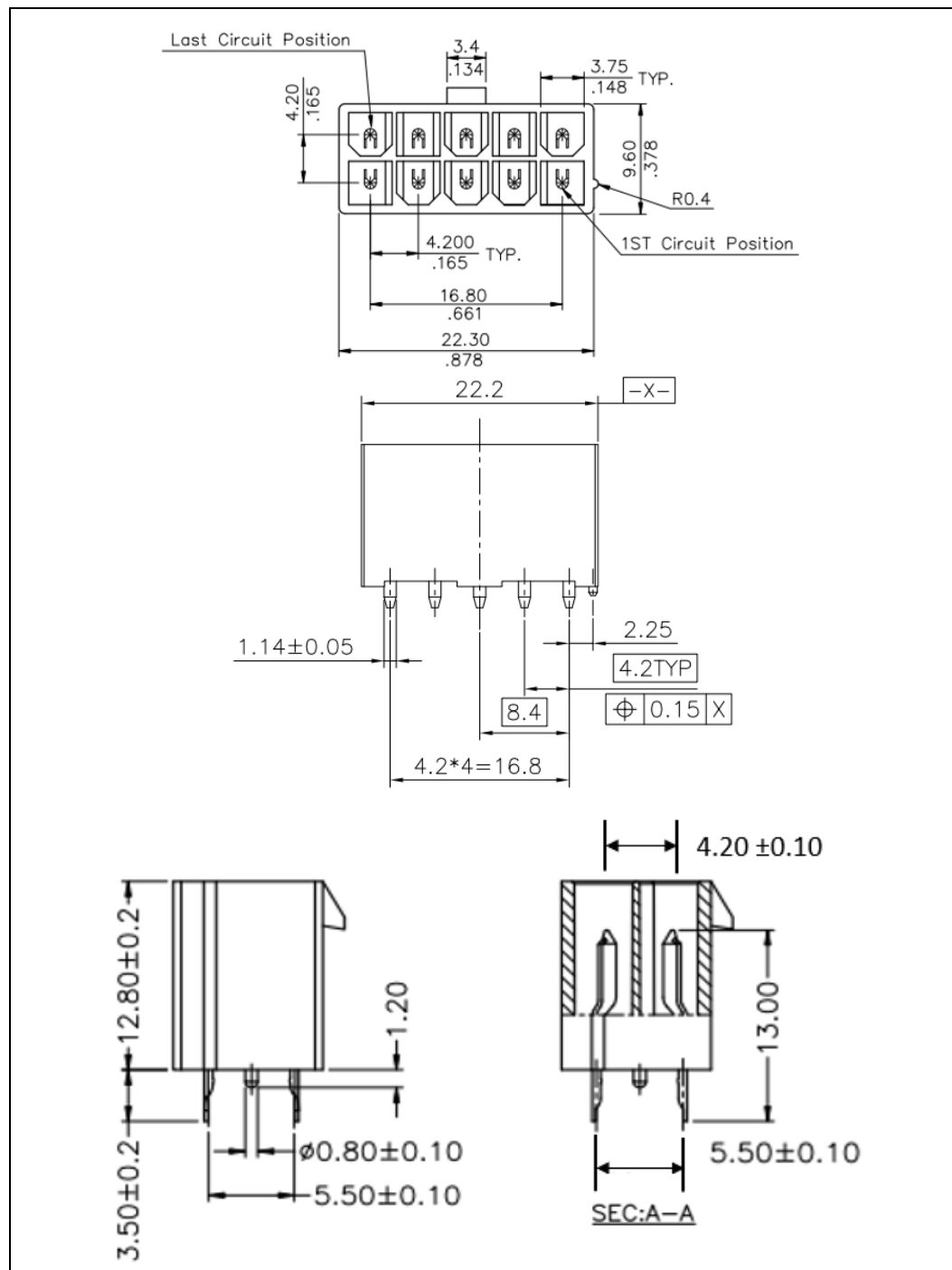
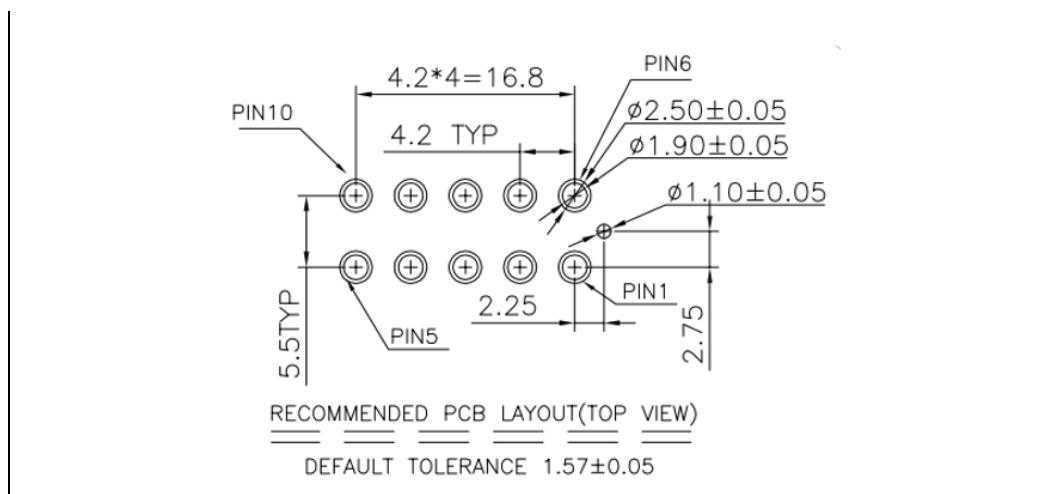


Figure 5-3: 4.2 mm Power Header 10 pin Main Power – Motherboard Connector, PC Board Layout with Dimensions





**Table 5-2: Main Power Connector Pinout**

Pin	Signal	Color	Pin	Signal	Color
1	PS_ON#	Green	6	PWR_OK	Gray
2	COM	Black	7	+12VSB	Purple
3	COM	Black	8	+12V1 DC	Yellow
4	COM	Black	9	+12V1 DC	Yellow
5	I_PSU%	Blue	10	+12V1 DC [12V Sensing Pin]	Yellow [Brown]

This power connector is designed as the main board connector and for smaller to medium size boards this is the only connector that is needed. This connector can provide up to 216 to 288 watts of power using the assumption that each pin can provide 6–8 Amps. Board designers need to figure out total board power and if this single connector provides enough power for each board.

Pin 10 is used for both main 12V Power and the optional Voltage Sensing wire for the power supply to provide the correct voltage to the motherboard. Voltage Sensing Pin details in Section [4.2.3](#).

### 5.2.2.2 Extra Board Connector (Based on PSU Size)

If board power requirements are higher than what can be provided by the 10 pin Main Board Connector, the Extra Board Power connector can be used. This connector can provide an additional 216-288 watts of power to the motherboard to support multiple PCIe\* connectors, multiple USB ports, or other expansion slots.

Two connectors can also be used if the 240VA Safety requirements are needed for the PSU.

Since the Extra Board Connector is optional on the motherboard and is expected to be needed only for higher power motherboards, this can be correlated to PSU size.

Therefore, this connector is only required on PSU that are greater than 450 Watts. It is optional on PSU that is equal to or less than 450 Watts.

**Table 5-3: Extra Board Connector – Required vs. Optional**

Rated PSU Size	Required vs. Optional
≤450 Watts	Optional
>450 Watts	Required

This connector has the same mechanical and electrical characteristics as the PCIe\* 2x3 Auxiliary Power Connector, detailed in Section 5.2.2.4.1.

**Table 5-4: Extra Board Power Connector 6 Pin Connector Pinout**

Pin	Signal	Color <sup>1</sup>	Pin	Signal	Color <sup>1</sup>
1	+12V1	Yellow	4	COM	Black
2	+12V1	Yellow	5	COM	Black
3	+12V1	Yellow	6	COM	Black

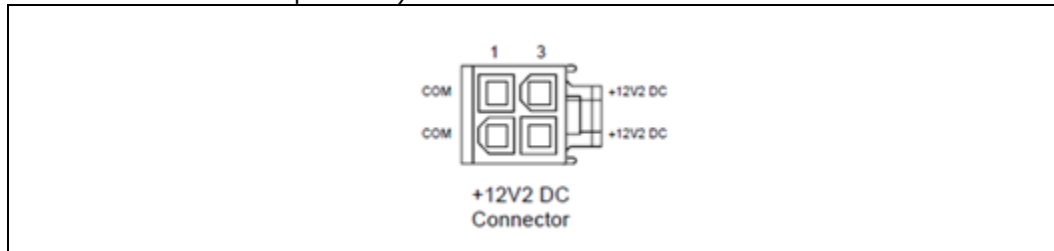
**NOTE:**

1. 18 AWG wire.

### 5.2.2.3 +12V CPU Power Connector (Required)

Connector: Molex\* 0039012040 or equivalent.

Contact: Molex\* 44476-1112 (HCS) or equivalent (Mating motherboard connector is Molex 39-29-9042 or equivalent).



**Table 5-5: +12V Power 4 pin Connector Pinout**

Pin	Signal	Color <sup>1</sup>	Pin	Signal	Color <sup>1</sup>
1	COM	Black	3	+12V2 DC	Yellow
2	COM	Black	4	+12V2 DC	Yellow

**NOTE:**

1. 18 AWG wire.

**Table 5-6: +12V Power 8 pin Connector Pinout**

Pin	Signal	Color <sup>1</sup>	Pin	Signal	Color <sup>1</sup>
1	COM	Black	5	+12V2 DC	Yellow
2	COM	Black	6	+12V2 DC	Yellow
3	COM	Black	7	+12V2 DC	Yellow
4	COM	Black	8	+12V2 DC	Yellow

**NOTE:**

1. 18 AWG wire.

**5.2.2.4 PCI Express\* (PCIe\*) Add-in-Card Connectors (Recommended)**

These are optional connectors for the power supply to support additional power needed by any PCI Express\* Add-in Card (AIC). The most common PCIe\* Add-in Card that uses these connectors are discrete graphics cards. The PCIe\* CEM Specification defines different connectors based on the power used by the Add-in Card which can range from 75 watts up to 600 watts.

**5.2.2.4.1 PCI Express\* (PCIe\*) 2x3 Auxiliary Power Connector (Recommended)**

The 2x3 Power Connector is designed to provide 75 watts to the PCIe\* Add-In-Card(s) and has the following requirements:

- Current Rating: 8.0 A/pin/position maximum to a 30 °C T-Rise above ambient temperature conditions at +12 VDC, all six contacts energized.
- Mated Connector Retention: 30.00 N minimum when plug pulled axially.

**Cable Assembly Contact and Housing Details:**

- Housing Material: Thermoplastic
- Pin Contact Base Material: Brass alloy or equivalent
- Pin Contact Plating: Sn alloy
- Flammability: UL94V-1 Minimum - Material certification or certificate of compliance is required with each lot to satisfy the Underwriters Laboratories follow-up service requirements.
- Lead Free Soldering: Connector must be compatible with lead free soldering process

**Table 5-7: PCIe\* 2x3 Auxiliary Power Connector Pin Assignment (75 Watts)**

Pin	Signal	Color <sup>1</sup>	Pin	Signal	Color <sup>1</sup>
1	+12V3/V4	Yellow	4	COM	Black
2	+12V3/V4	Yellow	5	Sense <sup>2</sup>	Black
3	+12V3/V4	Yellow	6	COM	Black

**NOTE:**

1. Wire Size: 18 AWG

2. The Sense pin on the 2x3 auxiliary power connector must be connected to ground either directly in the power supply or via a jumper to an adjacent ground pin in the connector. This pin is used by a PCI Express 2x3 150 W/225 W/300 W Add-in Card to detect if the 2x3 auxiliary power connector is attached.

#### 5.2.2.4.2 PCI Express\* (PCIe\*) 2x4 Auxiliary Power Connector (Recommended)

The 2x4 Auxiliary Power Connector consists of a *PCB\_ Header*, mounted on a PCIe\* Add-in Card, and a mating 2x4 *Cable Plug* harness. The 2x4 PCB header is designed to accept both the mating 2x4 Cable Plug as well as the 2x3 cable plug, for backward-compatibility. The Add-in Card PCB Header is keyed to ensure that a 2x3 cable plug from a PSU will be properly aligned when it is mated with a 2x4 PCB Header. Two Sense pins in the 2x4 PCB header allow the PCIe\* Add-in Cards to detect the power available from the cable. The 2x4 Cable Plug asserts (grounds) two sense pins to indicate that 150 watts are available to the PCIe\* Add-in Card through this cable, while the 2x3 plug asserts only one sense pin, to signal that only 75 W may be drawn from the cable. The 2x4 Cable Plug has the following requirements:

- Current Rating: 7.0 A per pin/position maximum to a 30°C T-Rise above ambient temperature conditions at +12 VDC with all eight contacts energized
- Mated Connector Retention: 30.00 N minimum when plug pulled axially

#### Cable Assembly Contact and Housing Details:

- Housing Material: Thermoplastic; Note that this connector has unique mechanical keying to avoid wrongful insertion of cable plug meant for different types of connectors.
- Pin Contact Base Material: Brass alloy or equivalent
- Pin Contact Plating: Sn alloy
- Flammability: UL94V-1 Minimum - Material certification or certificate of compliance is required with each lot to satisfy the Underwriters Laboratories follow-up service requirements.
- Lead Free Soldering: Connector must be compatible with lead free soldering process

**Table 5-8: PCIe\* 2x4 Auxiliary Power Connector Pin Assignment (150 Watts)**

Pin	Signal	Color <sup>1</sup>	Pin	Signal	Color <sup>1</sup>
1	+12V3/V4	Yellow	5	COM	Black
2	+12V3/V4	Yellow	6	Sense0	Black
3	+12V3/V4	Yellow	7	COM	Black
4	Sense1	Black	8	COM	Black

**NOTE:**

1. 18 AWG wire.



**Table 5-9: PCIe\* 2x4 Auxiliary Power Connector Sense Pin Decoding by AIC**

Sense1	Sense0	Description
Ground	Ground	A 2x4 connector is plugged into the card. The card can draw up to 150 W from the auxiliary power connector
Ground	Open	Reserved
Open	Ground	A 2x3 connector is plugged into the card. The card can only draw up to 75 W from the auxiliary power connection
Open	Open	No auxiliary power connector is plugged in

For a sense pin that needs to be grounded, it must be connected to ground either directly in the power supply or via a jumper to an adjacent ground pin in the connector

**5.2.2.4.3 PCI Express\* (PCIe\*) 12VHPWR Auxiliary Power Connector (Optional for PSU ≤ 450 Watts, Recommended for PSU > 450 Watts)**

The 12VHPWR Auxiliary Power connector is designed to deliver up to 600 watts directly to a PCIe\* Add-in Cards. This power connector is not compatible with the existing 2x3 or 2x4 auxiliary power connectors. The 12VHPWR connector power pins have a 3.0 mm spacing while the contacts in a 2x3 and 2x4 connector are on a larger 4.2 mm pitch. The 12VHPWR auxiliary power connector includes twelve large contacts to carry the power and four smaller contacts beneath carrying the sideband signals.

The connector performance requirements are as follows:

- Power Pin Current Rating: (Excluding sideband contacts) 9.2 A per pin/position with a limit of a 30 °C T-Rise above ambient temperature conditions at +12 VDC with all twelve contacts energized. The connector body must display a label or embossed H+ character to indicate support of 9.2 A/pin or greater. Refer for the approximate positioning of the marker on the 12VHPWR Right Angle (R/A) PCB Header.
- Mated Connector Latch Retention: 45.00 N minimum when plug pulled axially.

The 12VHPWR Connector has been defined with 2 options that provide different physical protections for the side-band signals.

Figure 5-4: 12VHPWR Cable Plug Connector

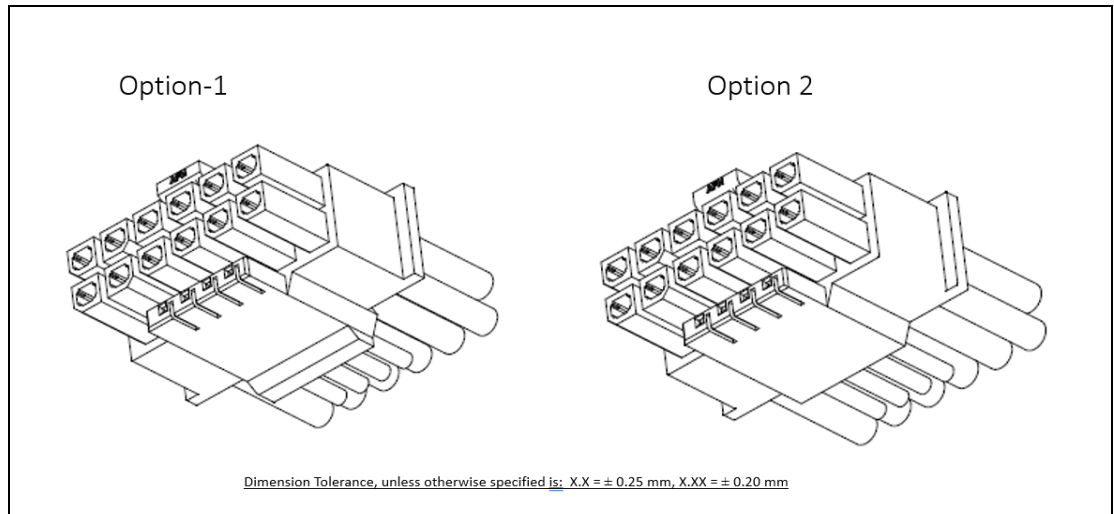
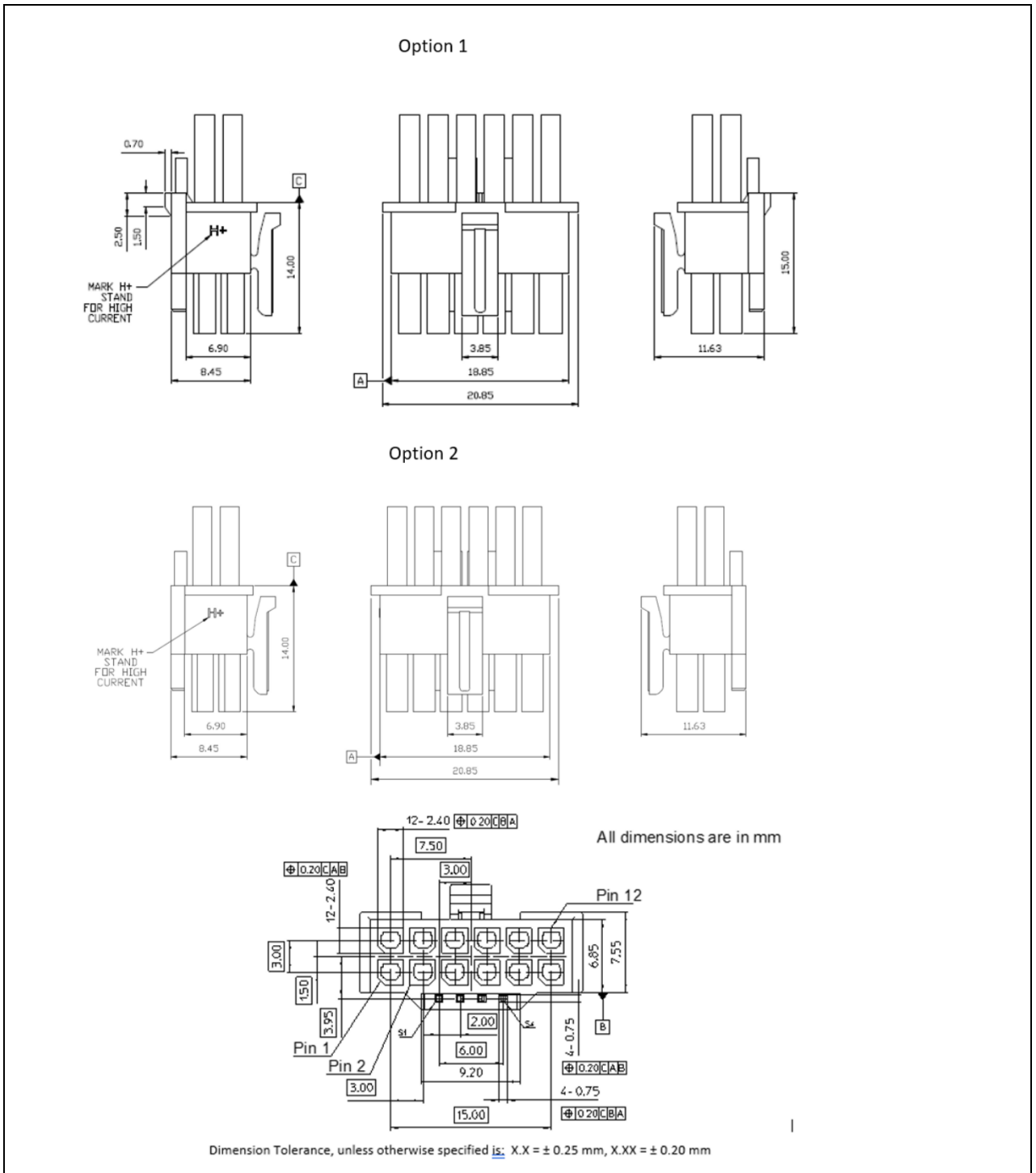


Figure 5-5: 12VHPWR Cable Assembly



The cable plug connector housing for the 12VHPWR connector has all dimensions shown in mm. Slight changes to this connector that do not affect mating with its

associated plug may happen. Reference the latest PCI-SIG documentation for any updates concerning information about this connector.

12VHPWR Cable Plug Assembly Contact and Housing Details:

- Housing Material: Thermoplastic Glass Fiber Filled, UL94V-0
- Color: Black
- Pin Contact Material: Copper Alloy
- Power Pin Contact Plating: Tin plated on contact area
- Signal Pin Contact Plating: Tin plated on contact area
- All dimensions are in mm
- Connector must be compatible with lead-free soldering process.

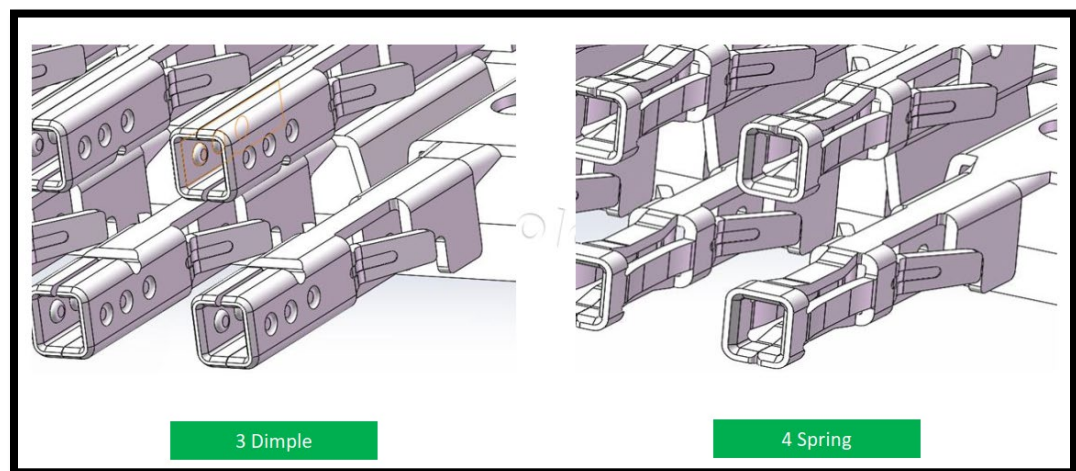
**Wire Details:**

- Power/Ground Pin Wire Size: 16 AWG
  - All 12 pins must be connected to the power supply using 16 AWG cable
- Sideband Signals Pin Wire Size: 28 AWG

12VHPWR Cable Plug Connection Recommendations

- Crimp Contacts inside of the cable plug are recommended to use the “4 Spring” design instead of “3 Dimple” design (as shown in Figure 5-6) which will increase the contact area for electrical current flow inside the 12VHPWR connector and reduce the temperature rise of each contact.  
Figure 5-6 image courtesy of Wieson Technologies Co., Ltd.

**Figure 5-6: 12VHPWR Cable Plug Connection Recommendation**



**Table 5-10: PCIe\* 12VHPWR Auxiliary Power Connector Pin Assignment (600 Watts)**

Pin	Signal	Color <sup>1</sup>	Pin	Signal	Color <sup>1</sup>
1	+12V3/V4	Yellow	7	COM	Black
2	+12V3/V4	Yellow	8	COM	Black
3	+12V3/V4	Yellow	9	COM	Black
4	+12V3/V4	Yellow	10	COM	Black
5	+12V3/V4	Yellow	11	COM	Black
6	+12V3/V4	Yellow	12	COM	Black
S1	CARD_PWR_STABLE	Blue	S3	SENSE0	Blue
S2	CARD_CBL_PRES#	Blue	S4	SENSE1	Blue

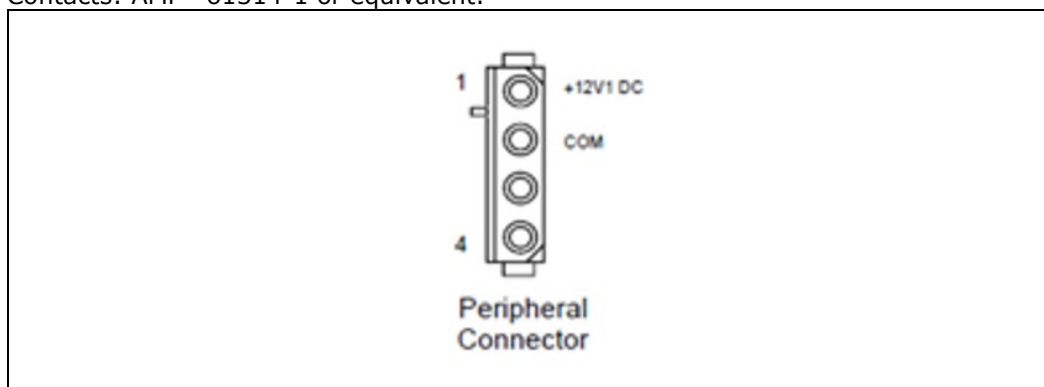
The electrical function for the sideband pins S1- S4 is detailed in Section 3.3 of this document.

### 5.2.2.5 Peripheral Connectors (Optional)

Recommended for PSU designed for High End Desktop and Gaming systems that might need 12V power for Fans, LEDs, or Liquid Cooling pumps. Only populate pins 1 and 2.

Connector: AMP\* 1-480424-0 or Molex\* 15-24-4048 or equivalent.

Contacts: AMP\* 61314-1 or equivalent.



**Table 5-11: Peripheral Connector Pinout**

Pin	Signal	Color <sup>1</sup>
1	+12V1 DC	Yellow
2	COM	Black
3	No connect	
4	No connect	

**NOTE:**

1. 18 AWG wire.

## 5.3 Connector from Motherboard to Storage Devices – Reference

Other components that require both 12V and 5V power like SATA Storage and Optical drives will now need to get their power from the motherboard. The motherboard will provide the voltage regulator that converts 12V power into 5V. This connector needs to be **Black** for both the cable and board connector to easily identify that power is coming out of the power and is not a connector that needs power from the power supply.

This is included in the power supply design guide to provide an industry standard connection from motherboard to these Storage and/or other devices using these connectors.

### 5.3.1 Motherboard Connector

Motherboard needs to provide power for Storage devices because they need both 12V and 5V. The motherboard is recommended to provide power to either 4, 6, or 8 storage drives. Current and near future platforms support 6–8 SATA connections. Based on market, board size and cost considerations the amount of storage drives supported needs to be considered. Based on per storage drive max requirements of 12V @ 2-2.5 amps and 5V @ 1 amp, below are details for two options. If per drive power increases, then number of drives per connector would also change.

Two connector options listed below to support 2 drives or 4 drives per connector based on motherboard need. Both connector options follow the **3 mm ATX12VO SATA Power Header** dual row vertical through hole product type. These connectors must support 5A per pin.

#### 5.3.1.1 Supporting 2 SATA Drives with 4 Pin Connector Details

**Table 5-12: 3 mm SATA Power 4 Pin Connector Part Numbers**

Company	Motherboard Connector Part Number	SATA Power Cable Connector Part Number
Amphenol*	10157705-041B2GLF	10157706-04B20LF
Foxconn*	HMHA020-L2G31-4G	---
JOINT TECH ELECTRONIC*	C3030WVF-F-2X02PNLBM1N00B	C3030HFF-2X02PN0BNPN00G
Lotes*	APOW0041-P001A01	ABA-WAF-895-P01
Wieson*	AC2211-0009-001-HH	AB9001-0009-001-00

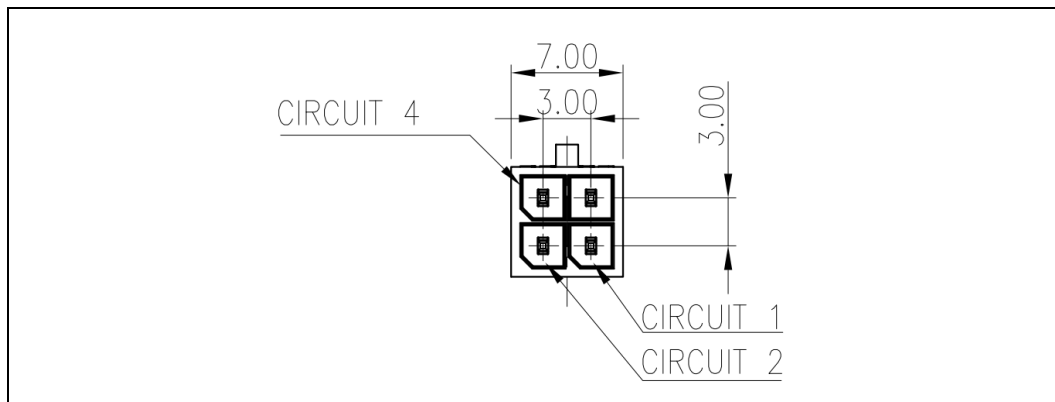
More connectors options may exist; Work with your preferred connector company to verify if they can provide the connector described in this document.

**Table 5-13: SATA MB Power 4 Pin Connector Pinout**

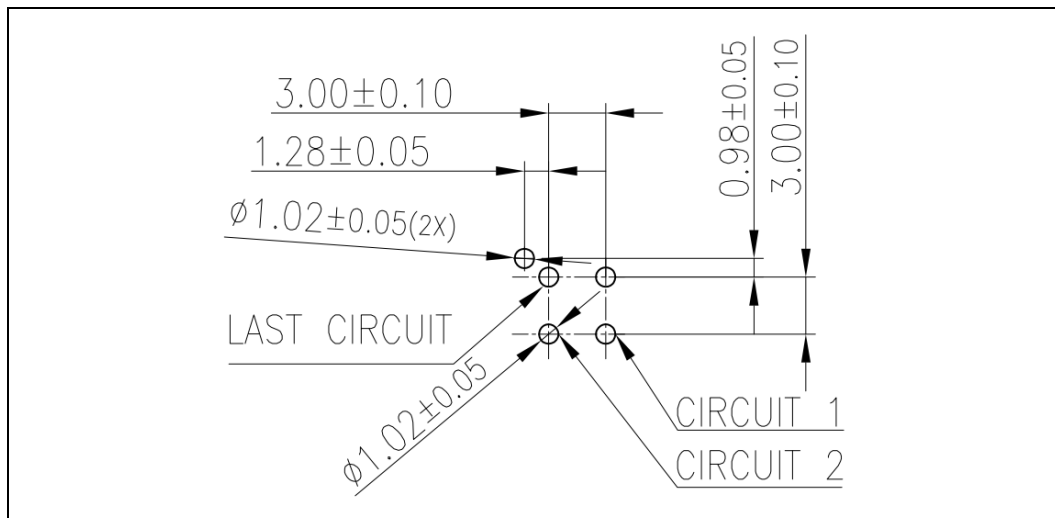
Pin#	Volts	Color <sup>1</sup>	Max Amp Per SATA HDD	Amp Per Conn Pin to Support 2 SATA Devices
1	GND	Black	1.02	2.04
2	GND	Black	2.5	5
3	12	Yellow	2.5	5
4	5	Red	1.02	2.04

The motherboard connection for this part does have 1 post that provides a mechanical key for the connection next to the last circuit, just like the 6-pin connector does.

**Figure 5-7: 3 mm SATA Power 4 Pin MB Header – Motherboard Connector Diagram (Pin Locations and Latch Location)**



**Figure 5-8: 3 mm SATA Power 4 Pin MB Header – Recommended PCB Layout (Top Layer View)**



The 4-pin storage drive connector option recommended cable has two storage drive connections over the length of the cable.

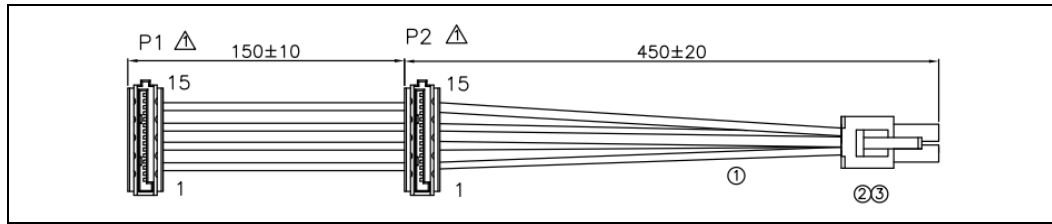
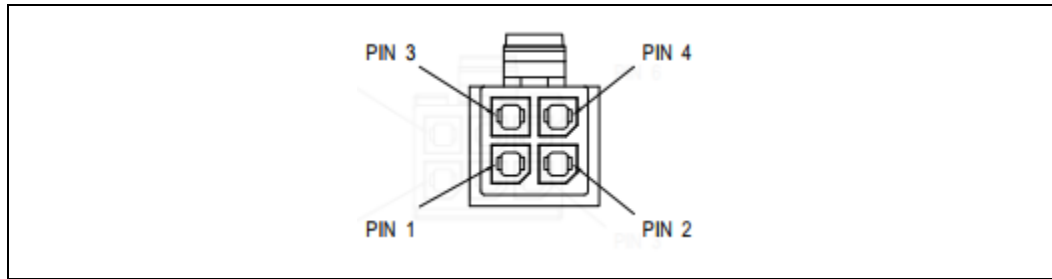


Figure 5-9: 3 mm SATA Power 4 Pin Cable Connector – Key and Pin Locations



SATA - 4 pin power cable that supports two SATA drives per cable is available from the following companies.

Table 5-14: 2 SATA Power Cable Part Numbers

Company	2 SATA Drive Cable
JOINT TECH ELECTRONIC*	W30050
Wieson*	AB9980-0341-008-00

Other cable companies may also be able to manufacturer this cable. Work with your preferred connector and cable company to verify if they can provide the SATA power cable described in this document.

### 5.3.1.2 Supporting 4 SATA Drives with 6 Pin Connector Details

If a system designer needs to support more than 2 SATA devices per connector on the board a 6-pin storage drive power connector is defined. With a total of 6 pins the number of SATA devices that can be supports is 4 devices. The Micro Fit connector will only support 5 amps per pin, because of that the 12V wire can only support 2 drives in Series. To support more than 2 drives the cable would have to be in a "Y" shape with 2 drives on each leg of the "Y". The 5V current is more than half of the 12V current therefore the one 5V pin can be used to support 4 SATA devices.

Using the 6-pin motherboard connection with the key solutions provided below allows both the 6 pin (2x3 – supporting 4 drives) and 4 pin (2x2 – supporting 2 drive) cables to be plugged into the 6 pin (2x3) motherboard connector. Notice the 6-pin motherboard connector latch is wider to support the latch from both the 4 pin (2x2) and 6 pin (2x3) cable connector.



**Table 5-15: 3 mm SATA Power 6 Pin Connector Part Numbers**

Company	Motherboard Connector Part Number	SATA Power Cable Connector Part Number
Amphenol*	10157705-061B2GLF	10157706-06B20LF
Foxconn*	HMHA030-L2G31-4G	---
JOINT TECH ELECTRONIC*	C3030WVF-F-2X03PNLBM1N00B	C3030HFF-2X03PN0BNPN00G
Lotes*	APOW0042-P001A01	ABA-WAF-896-P01
Wieson*	AC2211-0009-002-HH	AB9001-0009-002-00

More connectors options may exist; Work with your preferred connector company to verify if they can provide the connector described in this document.

**Table 5-16: +12 V Power 6 Pin Connector Pinout**

Pin #	Volts	Color	Max Amp Per SATA HDD	Amp Per Conn Pin to Support 3x SATA Devices	Amp Per Conn Pin to Support 4x SATA Devices
1	GND	Black	2.5	5	5
2	GND	Black	1.02	3.06	4.08
3	GND	Black	-	2.5	5
4	12	Yellow	2.5	5	5
5	5	Red	1.02	3.06	4.08
6	12	Yellow	-	2.5	5

**Figure 5-10: 3 mm SATA Power 6 Pin MB Header – Recommended PCB Layout (Top Layer View)**

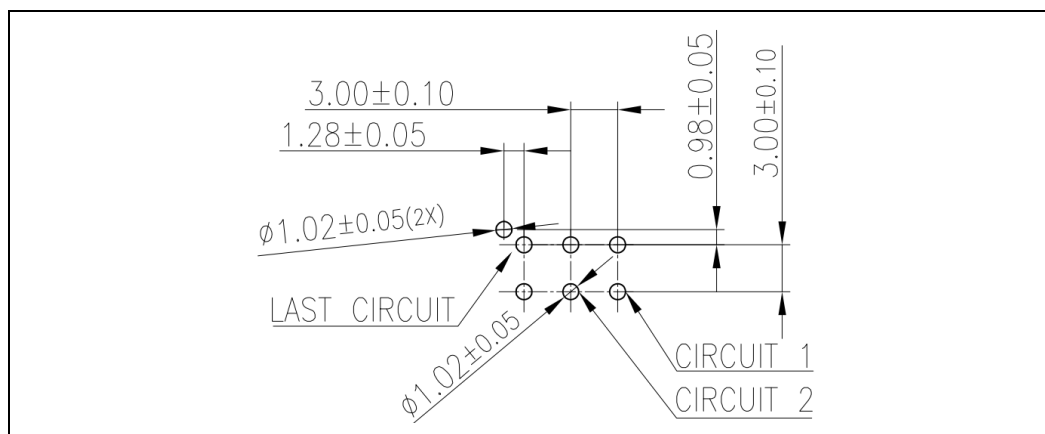
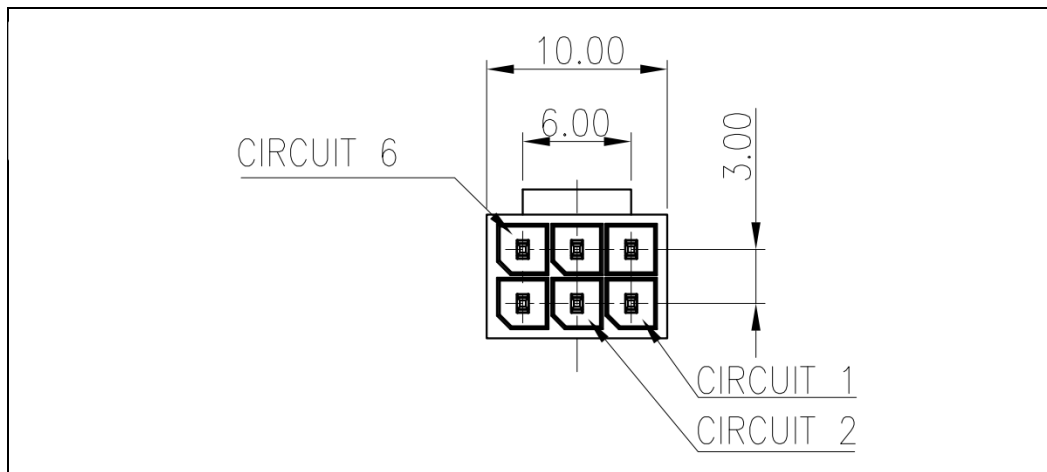


Figure 5-11: 3 mm SATA Power 6 Pin MB Header – Keying and Pin Locations



Cable design diagram. Both pins 2 and 5 would need to have 2 wires coming out of the one pin. Top view shows which cable is connected to each pin.

Figure 5-12: 3 mm SATA Power 6 pin/4 SATA Device Cable Diagram (Connector Top View)

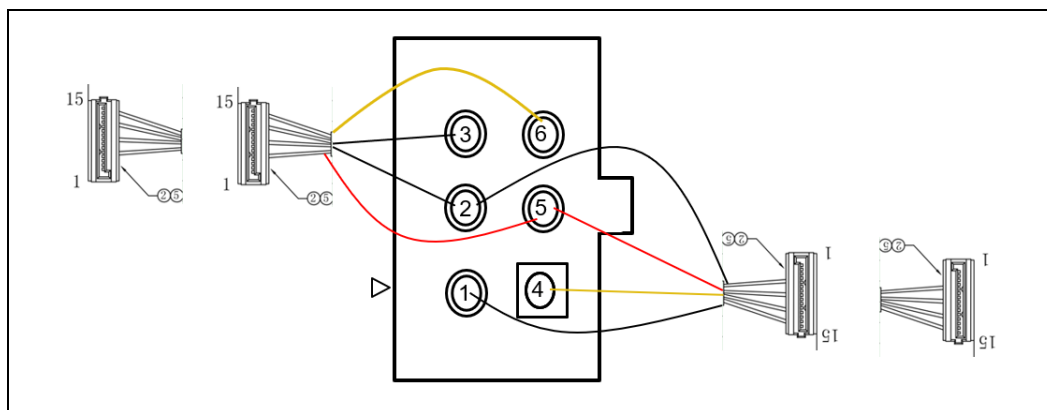
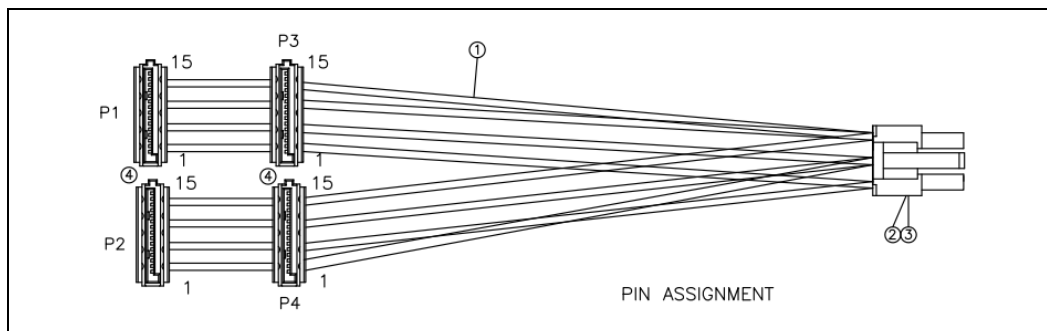
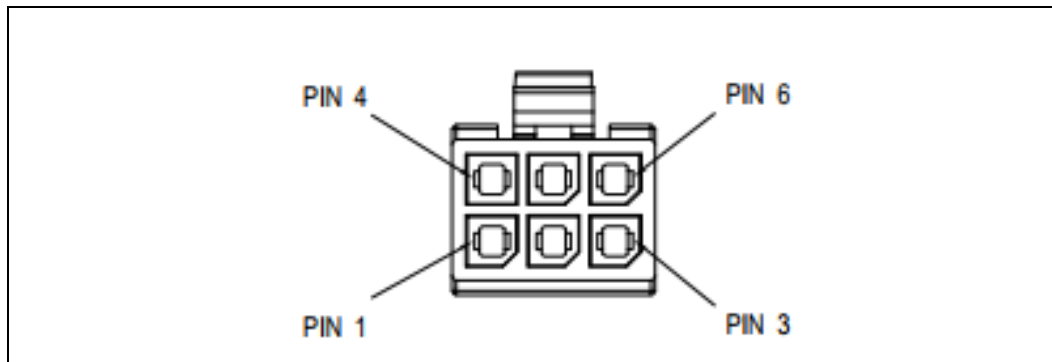


Figure 5-13: 3 mm SATA Power 6 Pin Cable Connector – Traditional Cable Diagram



**Figure 5-14: 3 mm SATA Power 6 Pin Cable Connector – Key and Pin Locations (Bottom View)**



SATA - 6 pin power cable that supports 4 SATA drives per cable is available from the following companies.

**Table 5-17: SATA Power Cable Supporting 4 SATA Devices Part Numbers**

Company	SATA Power Cable Supporting 4 SATA Devices
JOINT TECH ELECTRONIC*	W30051
Weison*	AB9980-0341-007-00

Other cable companies may also be able to manufacturer this cable. Work with your preferred connector and cable company to verify if they can provide the SATA power cable described in this document.

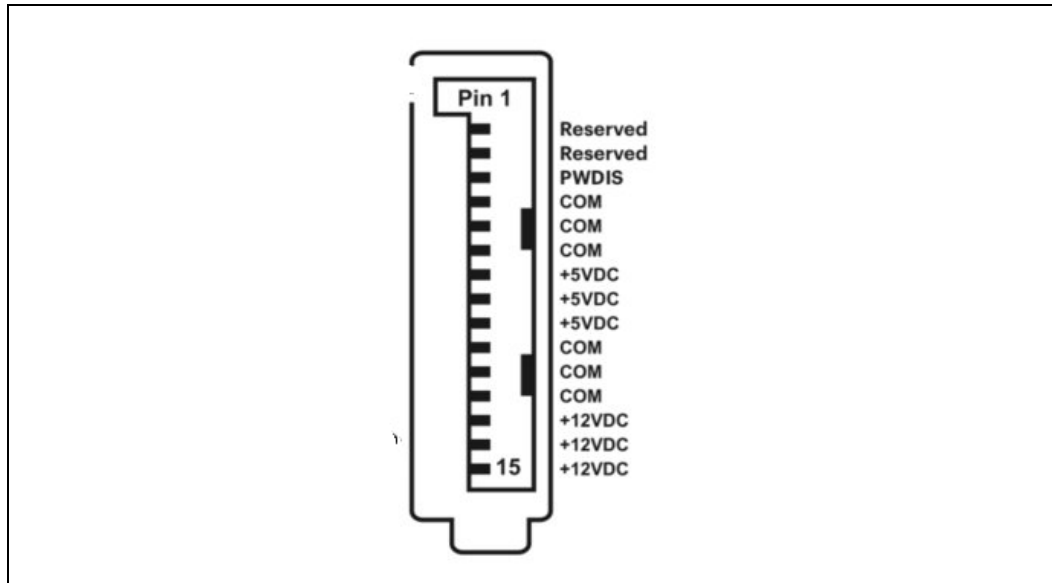
### 5.3.2 Serial ATA Connectors (Reference)

This connector will be used on the Storage Device cable coming from the motherboard.

This is a required connector for systems with Serial ATA devices. The detailed requirements for the Serial ATA Power Connector can be found in the *Serial ATA: High Speed Serialized AT Attachment Specification*, Section 6.3 *Cables and Connector Specification* (<http://www.serialata.org/>).

**Note:** Connector pin numbers and wire numbers are not 1:1. Carefully check to confirm the correct arrangement.

Assembly: Molex\* 88751 or equivalent.



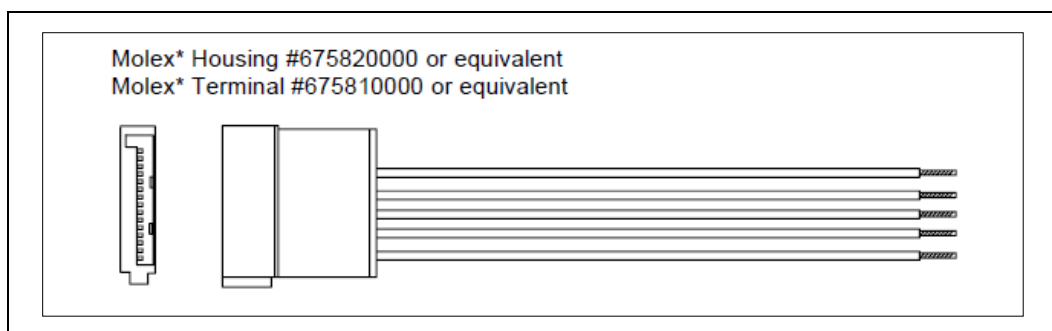
**Table 5-18: Serial ATA Power Connector Pinout**

Wire	Signal	Color <sup>1</sup>
5	n/c <sup>2</sup>	
4	COM	Black
3	+5V DC	Red
2	COM	Black
1	+12V1 DC	Yellow

**NOTES:**

1. 18 AWG wire.
2. +3.3V DC is removed from SATA V3.2 spec.

**Figure 5-15: Serial ATA Power Connector**



## 5.4 Airflow and Fans (Recommended)

The designer's choice of a power supply cooling solution depends in part on the targeted end-use system application(s). At a minimum, the power supply design shall ensure its own reliable and safe operation.

### 5.4.1 Fan Location and Direction

In general, exhausting air from the system chassis enclosure via a power supply fan at the rear panel is the preferred, most common, and most widely applicable system-level airflow solution. However, some system/chassis designers may choose to use other configurations to meet specific system cooling requirements.

### 5.4.2 Fan Size and Speed

A thermally sensitive fan speed control circuit is recommended to balance system-level thermal and acoustic performance. The circuit typically senses the temperature of the secondary heatsink and/or incoming ambient air and adjusts the fan speed as necessary to keep power supply and system component temperatures within specification. Both the power supply and system designers should be aware of the dependencies of the power supply and system temperatures on the control circuit response curve and fan size and should specify them carefully.

Fan should not turn on at the same time as PS\_ON# is Asserted. This is because of power optimization at low levels and Alternative Low Power Modes. Two options to consider:

1. Wait for at least 2 seconds before the fan turns on.
2. Fan must be turned ON only when the PSU needs the thermal cooling.

The power supply fan should be turned off when PS\_ON# is de-asserted (high). In this state, any remaining active power supply circuitry must rely only on passive convection for cooling.

### 5.4.3 Venting

In general, more venting in a power supply case yields reduced airflow impedance and improved cooling performance. Intake and exhaust vents should be large, open, and unobstructed as possible so as not to impede airflow or generate excessive acoustic noise. In particular, avoid placing objects within 0.5 inches of the intake or exhaust of the fan itself. A flush-mount wire fan grill can be used instead of a stamped metal vent for improved airflow and reduced acoustic noise.

The limitations to the venting guidelines above are:

- Openings must be sufficiently designed to meet the safety requirements described in Section [9](#).
- Larger openings yield decreased EMI-shielding performance. Refer to Section [8](#).
- Venting in inappropriate locations can detrimentally allow airflow to bypass those areas where it is needed.

**§§**

## 6 Acoustics

---

It is recommended that the power supply be designed with an appropriate fan, internal impedance, and fan speed control circuitry capable of meeting the acoustic targets listed in the below table.

The power supply assembly should not produce any prominent discrete tone determined according to ISO 7779, Annex D.

Sound power determination is to be performed at 43° C, at 50% of the maximum rated load, at sea level. This test point is chosen to represent the environment seen inside a typical system at the idle acoustic test condition, with the 43° C being derived from the standard ambient assumption of 23° C, with 20 C added for the temperature rise within the system (what is typically seen by the inlet fan). The declared sound power shall be measured according to ISO 7779 and reported according to ISO 9296.

Different customers might have different acoustic specifications. Any power supply design is recommended to follow any specific customer requirements.

**Table 6-1: Recommended Power Supply Acoustic Targets**

	Idle (BA)	Typical (50% load) (BA)	Maximum (BA)
<b>Minimum</b>	3.5	4.0	5.0
<b>Target</b>	3.0	3.8	4.5

§§

## 7 Environmental

---

The following subsections define environmental specifications and test parameters, based on the typical conditions to which a power supply may be subjected during operation or shipment.

### 7.1 Temperature (Recommended)

- Operating ambient +10 °C to +50 °C (At full load, with a maximum temperature rate of change of 5 °C/10 minutes, but no more than 10 °C/hr)
- Non-operating ambient -40 °C to +70 °C (Maximum temperature rate of change of 20 °C/hr)

### 7.2 Thermal Shock (Shipping)

- Non-operating -40 °C to +70 °C
- $15\text{ °C/min} \leq dT/dt \leq 30\text{ °C/min}$
- Tested for 50 cycles; Duration of exposure to temperature extremes for each half cycle shall be 30 minutes.

### 7.3 Humidity (Recommended)

- Operating to 85% relative humidity (non-condensing)
- Non-operating to 95% relative humidity (non-condensing)
- Note: 95% relative humidity is achieved with a dry bulb temperature of 55 °C and a wet bulb temperature of 54 °C.

### 7.4 Altitude (Recommended)

- Operating to 10,000 ft.
- Non-operating to 50,000 ft.

### 7.5 Mechanical Shock (Recommended)

- Non-operating 50 g, trapezoidal input; velocity change  $\geq 170\text{ in/s}$
- Three drops on each of six faces are applied to each sample.



## **7.6 Random Vibration (Recommended)**

- Non-operating  $0.01 \text{ g}^2/\text{Hz}$  at 5 Hz, sloping to  $0.02 \text{ g}^2/\text{Hz}$  at 20 Hz, and maintaining  $0.02 \text{ g}^2/\text{Hz}$  from 20 Hz to 500 Hz. The area under the PSD curve is 3.13 gRMS. The duration shall be 10 minutes per axis for all three axes on all samples.

**§§**

## 8 Electromagnetic Compatibility

---

The following subsections outline applicable product regulatory requirements for the power supplies. Additional requirements may apply dependent upon the design, product end use, target geography, and other variables.

### 8.1 Emissions (Required)

The power supply shall comply with FCC Part 15, EN55023 and CISPR 22, 5th ed., meeting Class B for both conducted and radiated emissions with a 4 dB margin. Tests shall be conducted using a shielded DC output cable to a shielded load. The load shall be adjusted as follows for three tests: No load on each output; 50% load on each output; 100% load on each output. Tests will be performed at 100 VAC 50Hz, 120 VAC 60 Hz, and 230 VAC 50 Hz power. Additionally, for FCC certification purposes, the power supply shall be tested using the methods in 47 CFR 15.32(b) and authorized under the Declaration of Conformity process as defined in 47 CFR 2.906 using the process in 47 CFR 2.1071 through 47 CFR 2.1077.

### 8.2 Immunity (Required)

The power supply shall comply with EN 55024 and CISPR 24 prior to sale in the EU (European Union), Korea, and possibly other geographies.

### 8.3 Input Line Current Harmonic Content (Optional)

Class D harmonic limits will be determined at the time of measurement based on the actual power draw from the mains.

The below table is a partial list of countries and their current EMC requirements. Additional requirements may apply dependent upon the design, product end use, target geography, and other variables.

**Table 8-1: EMC Requirement by Country**

Country	Requirements Document
EU (European Union)	EN61000-3-2
Japan	JEIDA MITI
China	CCC and GB 17625.1
Russia	GOST R 51317.3.2

### 8.4 Magnetic Leakage Field (Required)

A PFC choke magnetic leakage field shall not cause any interference with a high-resolution computer monitor placed next to or on top of the end-use chassis.

## **8.5 Voltage Fluctuations and Flicker (Required)**

The power supply shall meet the specified limits of EN61000-3-3 (IEC 61000-3-3) and amendment A1 to EN 61000-3-3 (IEC 61000-3-3/A1) for voltage fluctuations and flicker for equipment drawing not more than 16VAC, connected to low voltage distribution systems.

**§§**

## 9 Safety

---

The following subsections outline sample product regulations requirements for a typical power supply. Actual requirements will depend on the design, product end use, target geography, and other variables. Consult your company's Product Safety and Regulations department or an accredited third-party certification agency for more details.

### 9.1 North America (Required)

The power supply must be certified by an NRTL (Nationally Recognized Testing Laboratory) for use in the USA and Canada under the following conditions:

- The power supply UL report "Conditions of Acceptability" shall meet in the intended application of the power supply in the end product.
- The supply must be recognized for use in Information Technology Equipment including Electrical Business Equipment per UL 60950-1 First Edition. The certification must include external enclosure testing for the AC receptacle side of the power supply.
- The supply must have a full complement of tests conducted as part of the certification, such as input current, leakage current, hi-pot, temperature, energy discharge test, transformer output characterization test (open-circuit voltage, short-circuit performance), and abnormal testing (to include stalled-fan tests and voltage-select-switch mismatch).
- The enclosure must meet fire enclosure mechanical test requirements per clauses 2.9.1 and 4.2 of the above-mentioned standard.
- Production hi-pot testing must be included as a part of the certification and indicated as such in the certification report.
- There must not be unusual or difficult conditions of acceptability such as mandatory additional cooling or power de-rating. The insulation system shall not have temperatures exceeding their rating when tested in the end product.
- The certification mark shall be marked on each power supply.
- The power supply must be evaluated for operator-accessible secondary outputs (reinforced insulation) that meet the requirements for SELV.
- The proper polarity between the AC input receptacle and any printed wiring boards connections must be maintained (that is, brown=line, blue=neutral, and green=earth/chassis).
- The fan shall be protected by a guard to prevent contact by a finger in compliance with UL accessibility requirements.

### 9.2 International (Required)

The vendor must provide a complete CB certificate and test report to IEC 60950-1. The CB report must include ALL CB member country national deviations as appropriate for the target market. All evaluations and certifications must be for reinforced insulation between primary and secondary circuits.

The power supply must meet the RoHS requirements for the European Union, Peoples Republic of China and other countries which have adopted the RoHS requirements for banned materials.

### **9.3 Proscribed Materials (Required)**

The following materials must not be used during design and/or manufacturing of this product:

- Cadmium should not be used in painting or plating (Required).
- Quaternary salt and PCB electrolytic capacitors shall not be used (Required).
- CFC's or HFC's shall not be used in the design or manufacturing process (Required).
- Mercury shall not be used (Required).
- Some geographies require lead free or RoHS compliant power supplies (Required).

### **9.4 Catastrophic Failure Protection (Recommended)**

Should a component failure occur, the power supply should not exhibit any of the following:

- Flame
- Excessive smoke
- Charred PCB
- Fused PCB conductor
- Startling noise
- Emission of molten material
- Earth ground fault (short circuit to ground or chassis enclosure)



# 10 Reliability

---

## 10.1 Reliability (Recommended)

The de-rating process promotes quality and high reliability. All electronic components should be designed with conservative device de-ratings for use in commercial and industrial environments.

Electrolytic capacitor and fan lifetime and reliability should be considered in the design as well.

## 10.2 Reliability – PS\_ON# Toggle for S0ix Mode (Required)

Computer can periodically wake from S0ix depending on operation system, installed software, user interaction and other design implementation. Such wakes can have impact not only to the PSU reliability, but also be a source of end user annoyance with PSU fan spinning on then off again.

In order to optimize desktop platform power consumption, Intel provides design recommendation to enable power supply PS\_ON# toggle on/off during S0 idle power mode (S0ix) to save both system and PSU power. The power supply PS\_ON# signal may toggle on/off every 180s (PSU to be on for up to 1s and off for 180s) when customer desktop designs implement S0 idle which is different from the legacy desktop platform design that PS\_ON# only toggles once when turned on. The S0ix mode is used in systems that use Alternative Low Power Modes. This on / off toggling comes from scheduled OS maintenance tasks that occur in the background that necessitate bringing the PC on in order to execute CPU instructions.

Although the periodicity for on/off toggling is non-deterministic, it can happen regularly after the system has entered the S0ix idle mode with PS\_ON# de-asserted. If the computer turns on/off every 180 seconds, the worst-case scenario would be 480 times in one day and 175,200 times in one year. The power supply needs to be able to handle this many cycles for the life of the power supply.

To have a better user experience, and avoid PSU fan acoustic noise annoyance, system and PSU designers should have at least two seconds delay time for the PSU fan to spin up after PS\_ON# assertion. PSU is expected to support running at full load without any electrical, thermal components (i.e., IC, MOSFET, diode, transformer, inductor, capacitor, relay, fan, etc.) damaged or degradations during the period of time before the warranty expired. Due to the frequent PS\_ON# toggle on/off, system and PSU component's reliability should be considered based on the days, months, or years of claimed warranty listed on product specification. This is also mentioned in Section [5.4.2](#).



# 11 CFX12V Specific Guidelines 2.0

For Compact Form Factor with 12-volt connector power supplies.

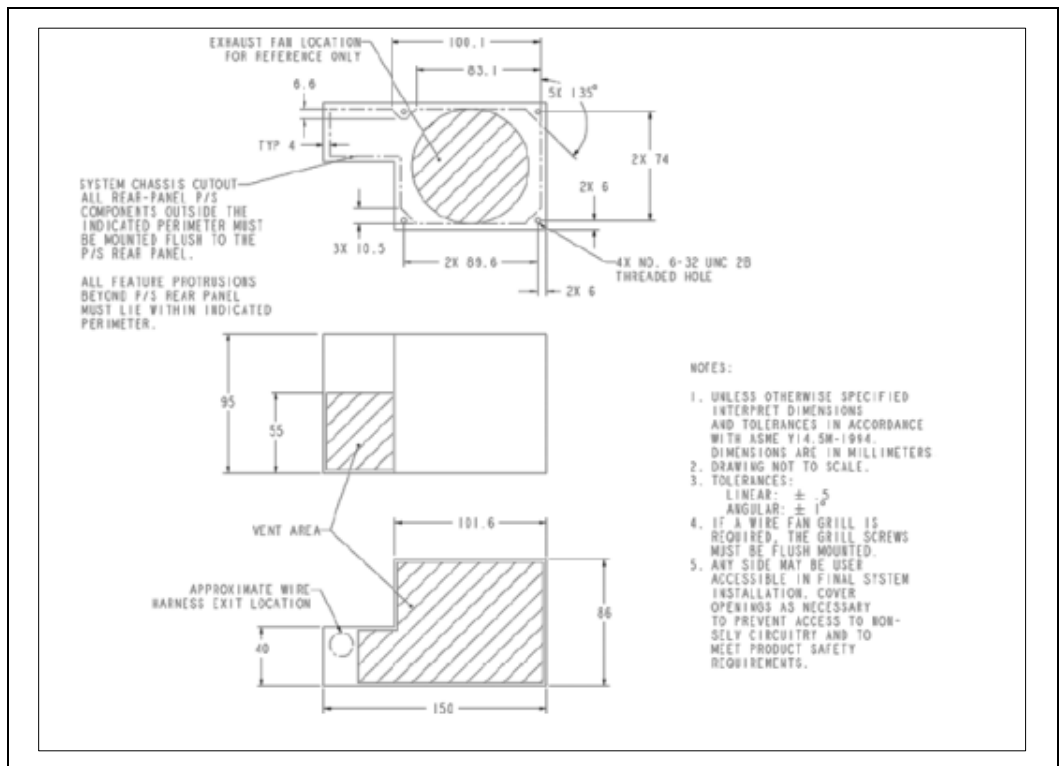
Mechanical dimension of power supplies has not changed from Multi Rail Desktop Power Supplies, so chassis do need not to change. Below are the current specifications for each size:

PSU DG	CFX12V	LFX12V	ATX12V	SFX12V	TFX12V	Flex ATX
2.0	2.0	2.0	3.0	4.0	3.0	2.0

## 11.1 Physical Dimensions (Required)

The power supply shall be enclosed and meet the physical outline shown.

Figure 11-1: CFX12V Mechanical Outline



§§

# 12 LFX12V Specific Guidelines 2.0

For Low Profile Form Factor with 12-volt connector power supplies.

Mechanical dimension of power supplies has not changed from Multi Rail Desktop Power Supplies, so chassis do need not to change. Below are the current specifications for each size:

PSU DG	CFX12V	LFX12V	ATX12V	SFX12V	TFX12V	Flex ATX
2.0	2.0	2.0	3.0	4.0	3.0	2.0

## 12.1 Physical Dimensions (Required)

The power supply shall be enclosed and meet the physical outline shown in [Figure 12-1](#), applicable. Mechanical details are shown in [Figure 12-2](#). Details on the power supply slot feature are shown in [Figure 12-3](#). The recommended chassis slot feature details are shown in [Figure 12-4](#).

**Figure 12-1: LFX 12V Mechanical Outline**

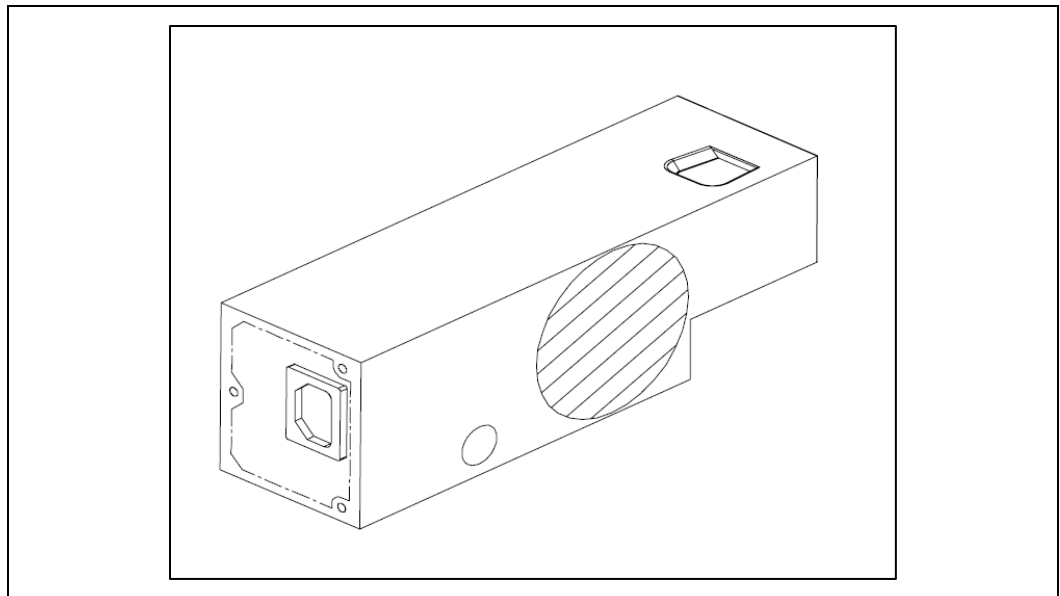




Figure 12-2: LFX 12V Mechanical Details

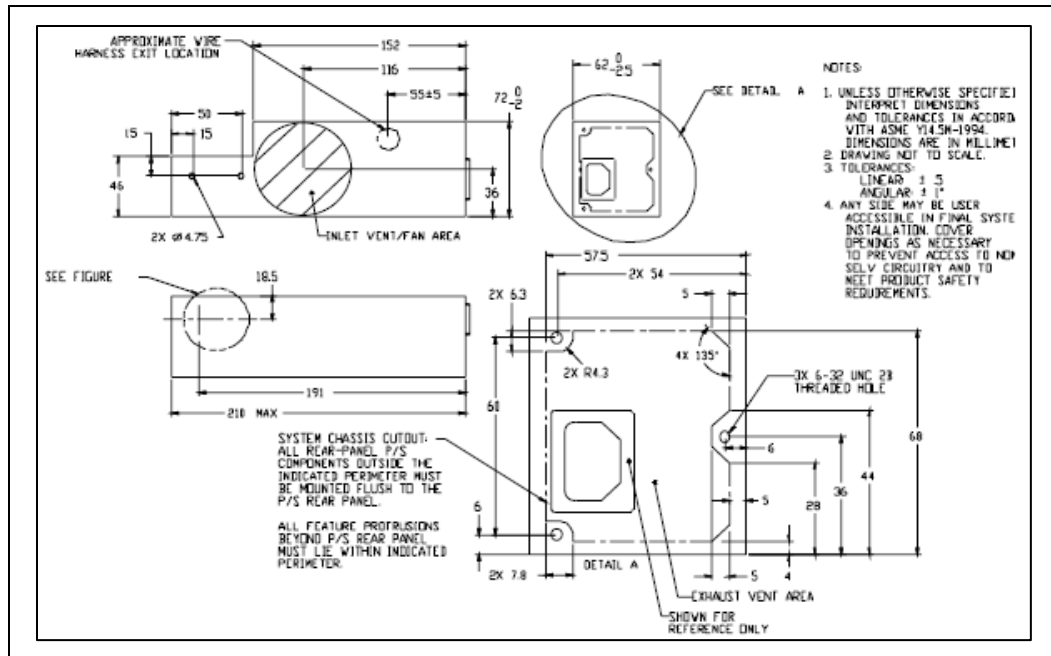


Figure 12-3: LFX 12V PSU Slot Feature Detail

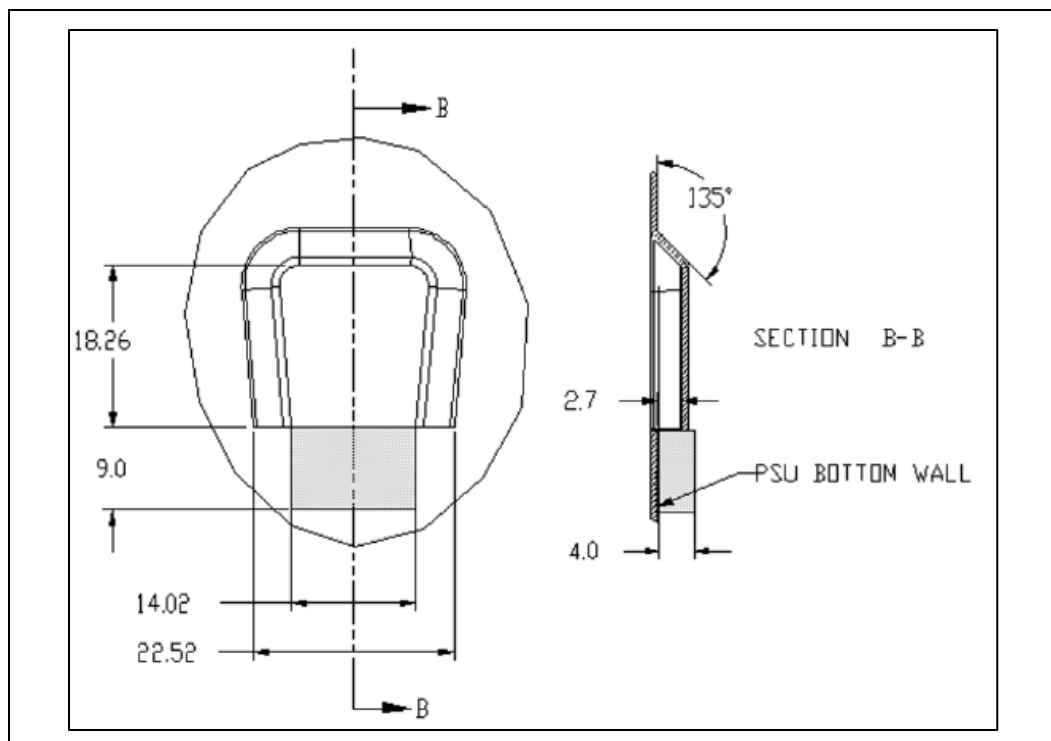
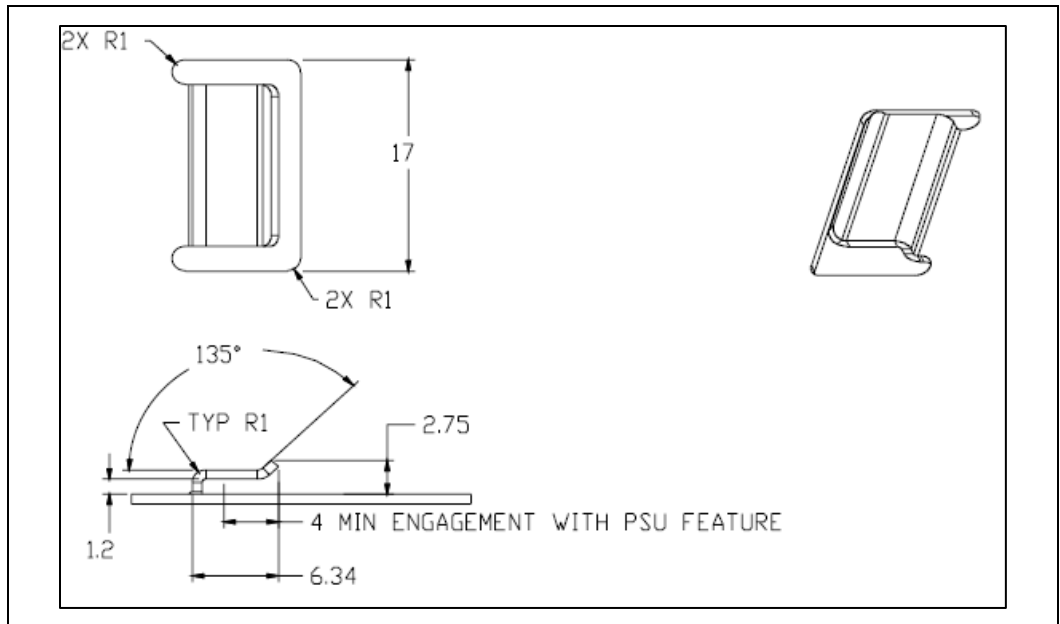


Figure 12-4: LFX 12V Recommended Chassis Tab Feature



SS

# 13 ATX12V Specific Guidelines 3.0

For ATX Form Factor with 12-volt connector power supplies.

Mechanical dimension of power supplies has not changed from Multi Rail Desktop Power Supplies, so chassis do need not to change. Below are the current specifications for each size:

PSU DG	CFX12V	LFX12V	ATX12V	SFX12V	TFX12V	Flex ATX
2.0	2.0	2.0	3.0	4.0	3.0	2.0

**Figure 13-1: ATX12V Power Supply Dimensions for Chassis Not Requiring Top Venting**

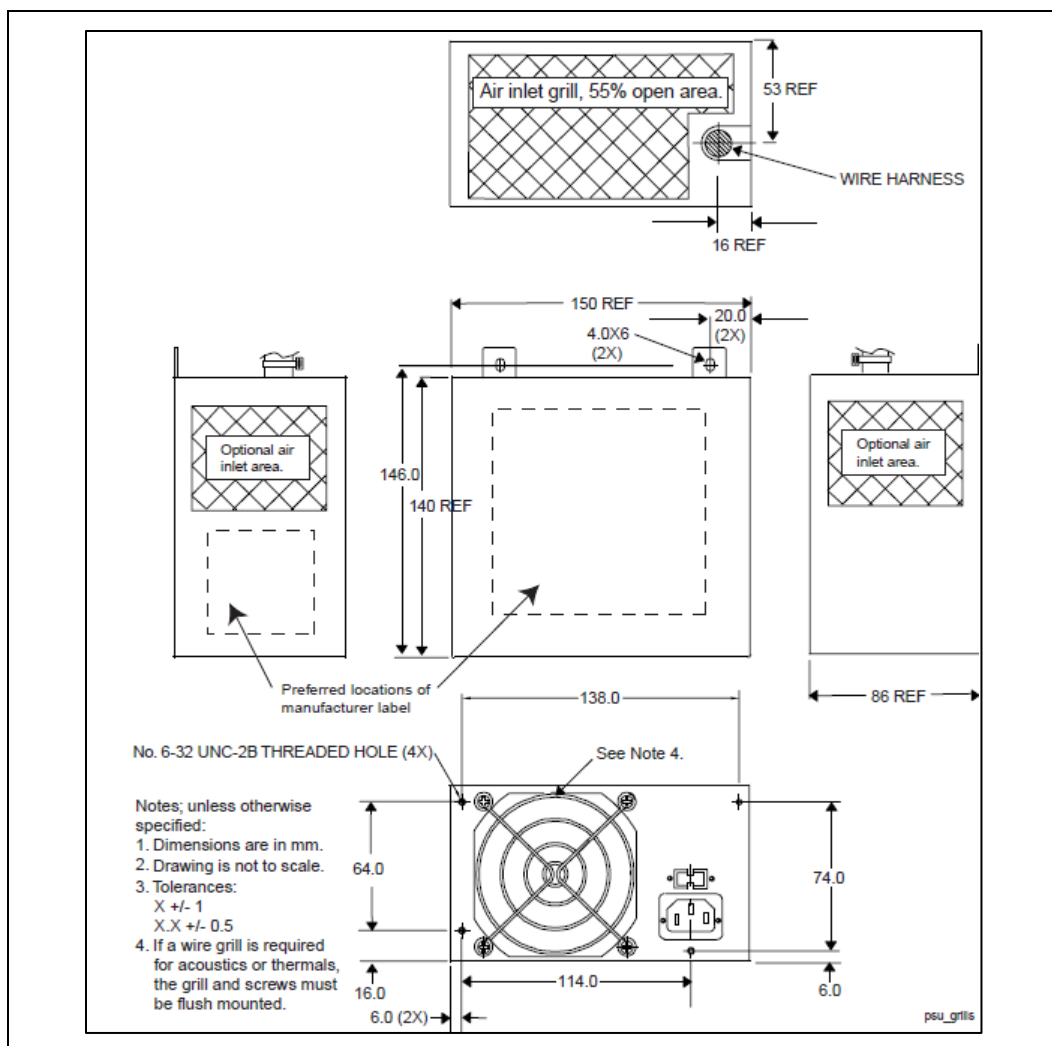
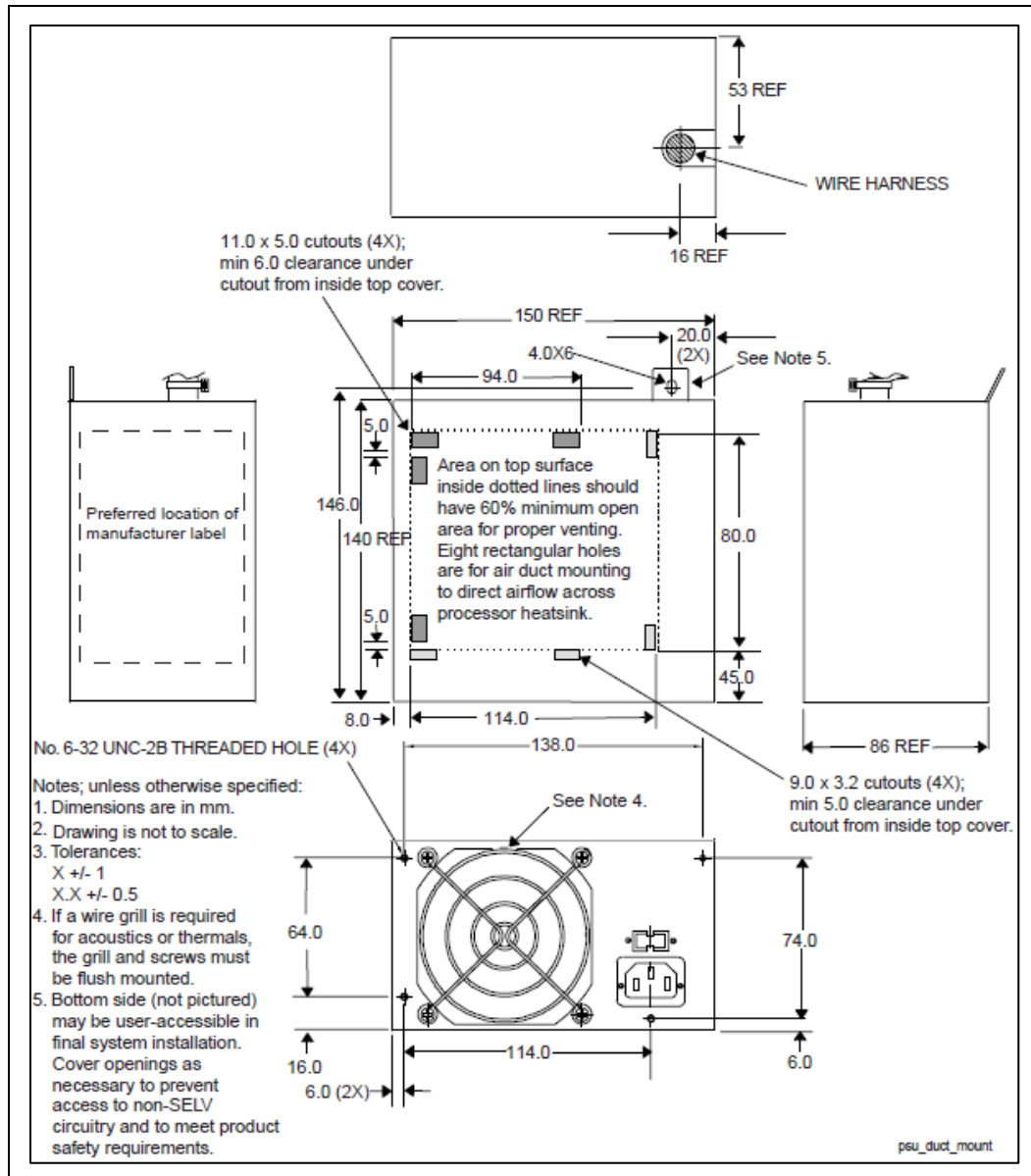


Figure 13-2: ATX12V Power Supply Dimensions for Chassis that Require Top Venting



§§

## 14 SFX12V Specific Guidelines 4.0

---

For Small Form Factor with 12-volt connector power supplies.

Mechanical dimension of power supplies has not changed from Multi Rail Desktop Power Supplies, so chassis do need not to change. Below are the current specifications for each size:

PSU DG	CFX12V	LFX12V	ATX12V	SFX12V	TFX12V	Flex ATX
2.0	2.0	2.0	3.0	4.0	3.0	2.0

### 14.1 Lower Profile Package – Physical Dimensions (Required)

The power supply shall be enclosed and meet the physical outline shown in [Figure 14-1](#).

### 14.2 Fan Requirements (Required)

The fan will draw air from the computer system cavity pressurizing the power supply enclosure. The power supply enclosure shall exhaust the air through a grill located on the rear panel. Refer to [Figure 14-2](#). The movement of the fan to the computer system cavity is to help limit the acoustic noise of the unit.

The fan will be 40 mm.

Figure 14-1: SFX12V 40 mm Profile Mechanical Outline

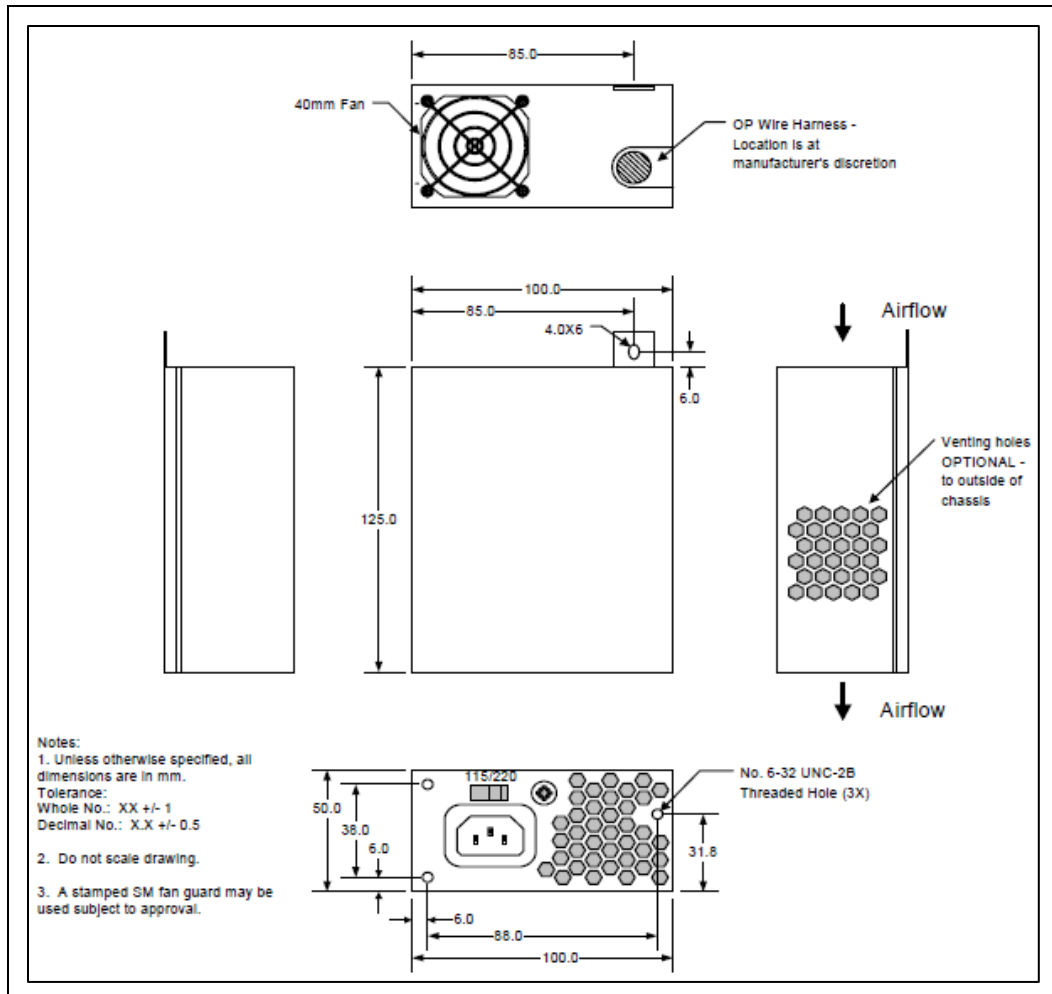
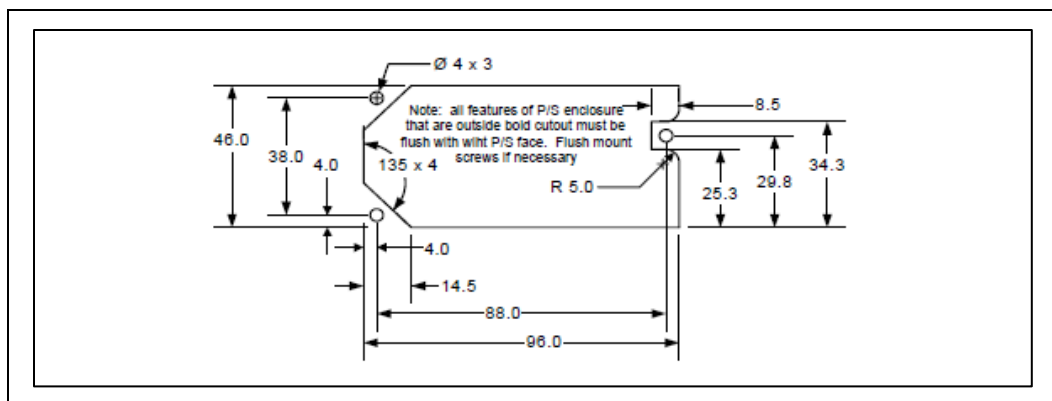


Figure 14-2: SFX121V Chassis Cutout



### **14.3 Top Fan Mount Package – Physical Dimensions (Required)**

The power supply shall be enclosed and meet the physical outline shown in [Figure 14-3](#).

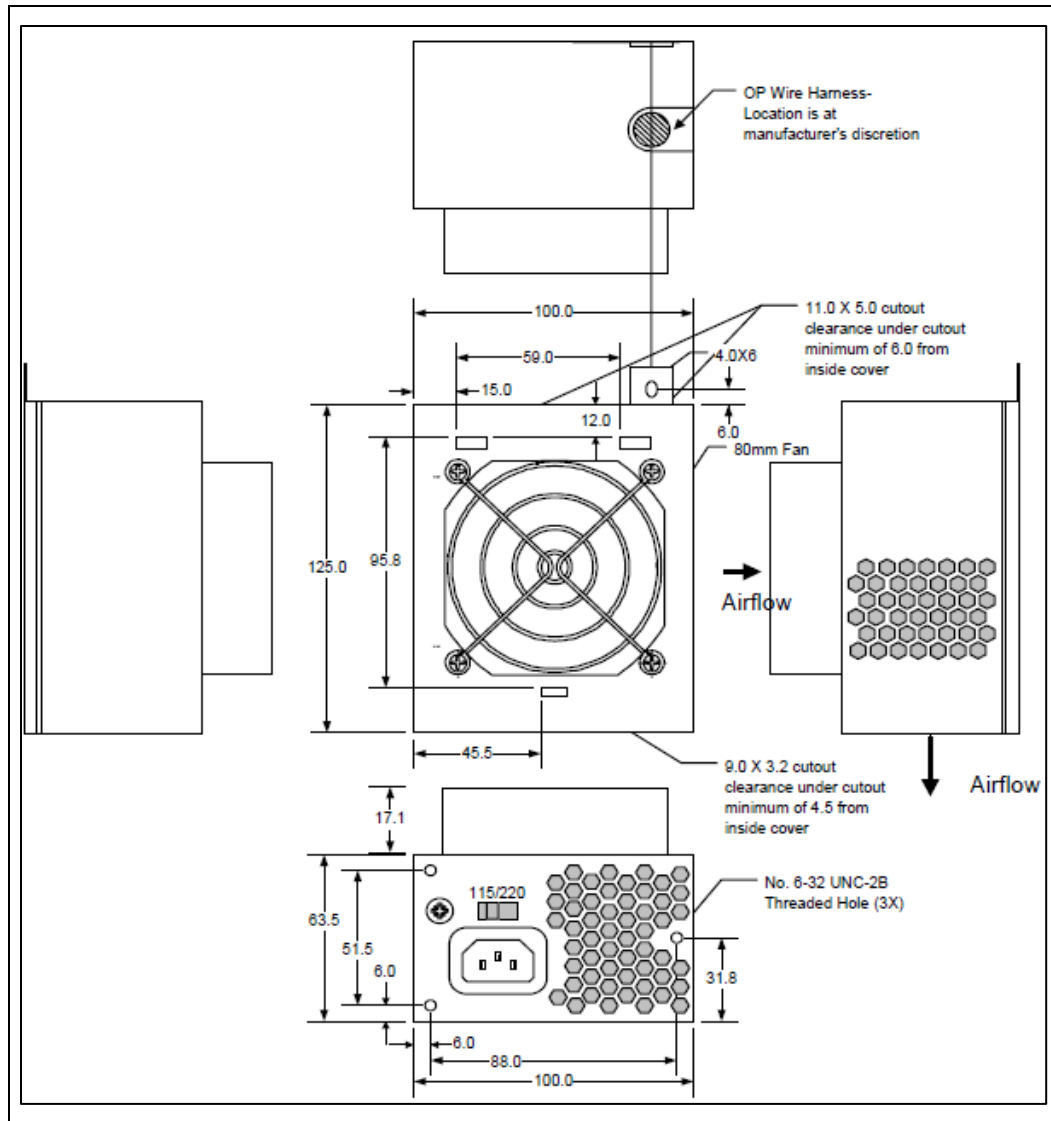
### **14.4 Fan Requirements (Required)**

The fan will draw air from the computer system cavity pressurizing the power supply enclosure. The power supply enclosure shall exhaust the air through a grill located on the rear panel. Refer to Moving the fan to the computer system cavity helps to limit the acoustic noise of the unit.

The fan will be 80 mm.

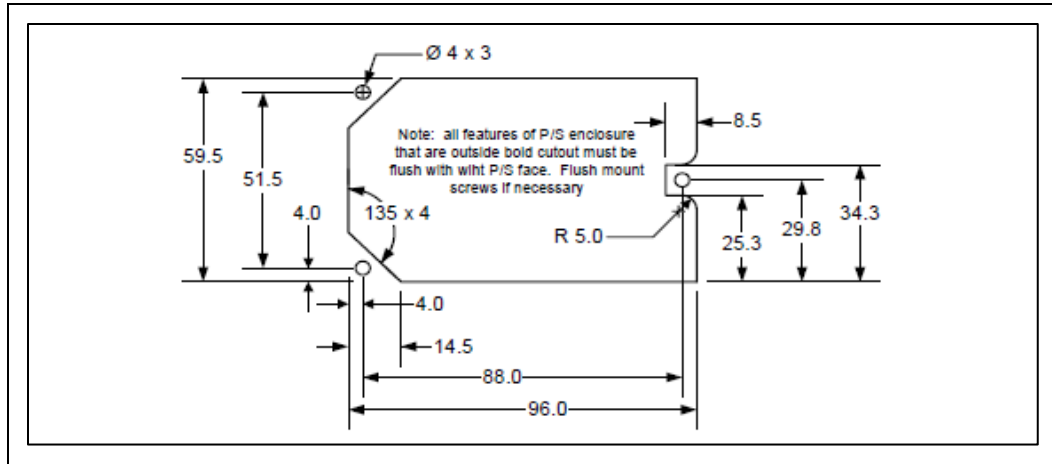
To prevent damage to the fan during shipment and handling, the power supply designer should consider recessing the fan mounting, as shown in [Figure 14-5](#).

Figure 14-3: SFX12V Top Mount Fan Profile Mechanical Outline

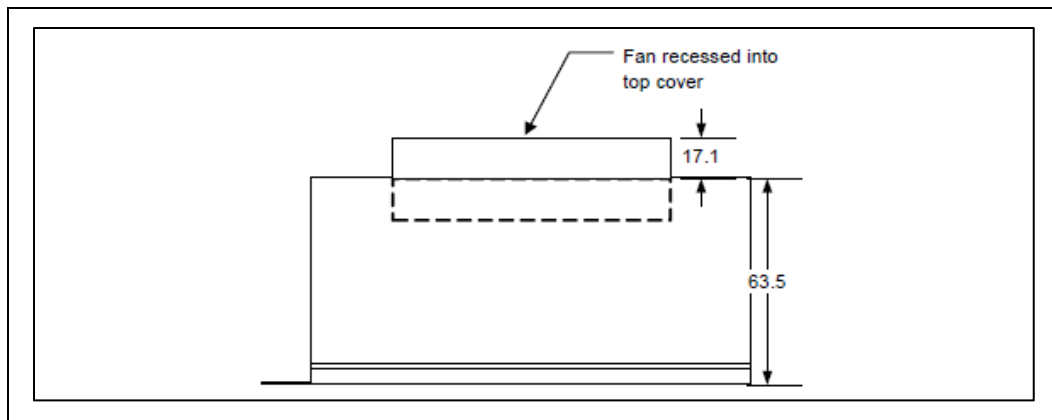




**Figure 14-4: SFX12V Chassis Cutout**



**Figure 14-5: SFX12V Recessed Fan Mounting**



## 14.5 Reduced Depth Top Mount Fan – Physical Dimensions (Required)

The power supply shall be enclosed and meet the physical outline shown in the below figure.

## 14.6 Fan Requirements (Required)

The fan will draw air from the computer system cavity pressurizing the power supply enclosure. The power supply enclosure shall exhaust the air through a grill located on the rear panel. Refer to [Figure 14-7: SFX12V Top Mount Fan, Inside enclosure Mechanical Outline \(Possible Larger Fan\)](#)

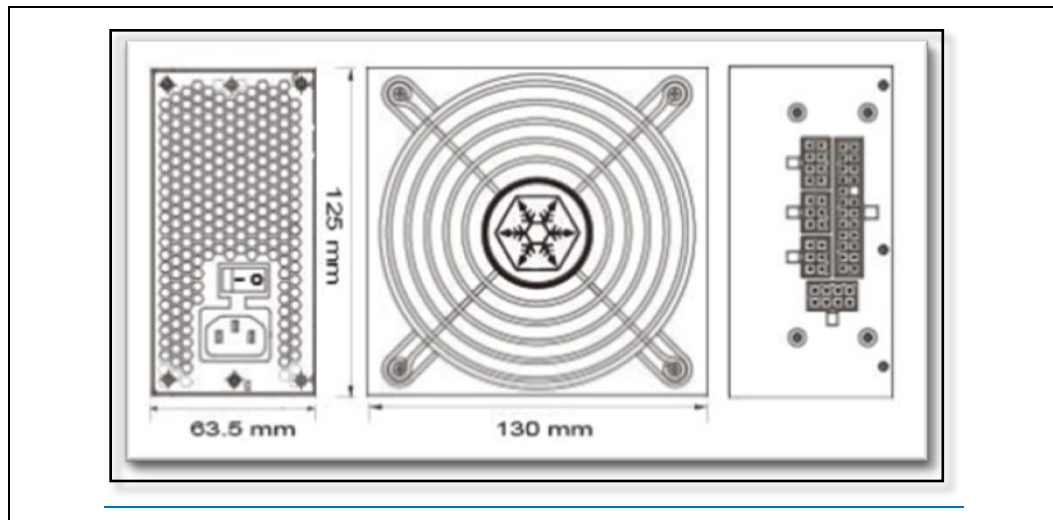
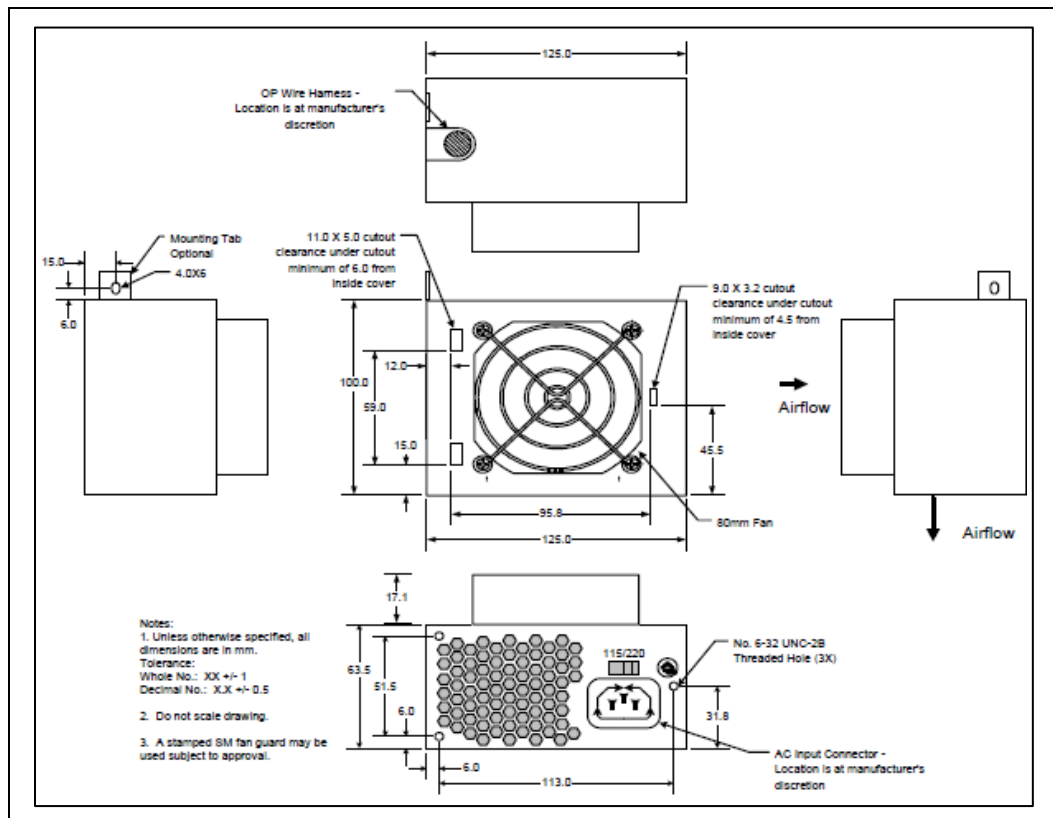


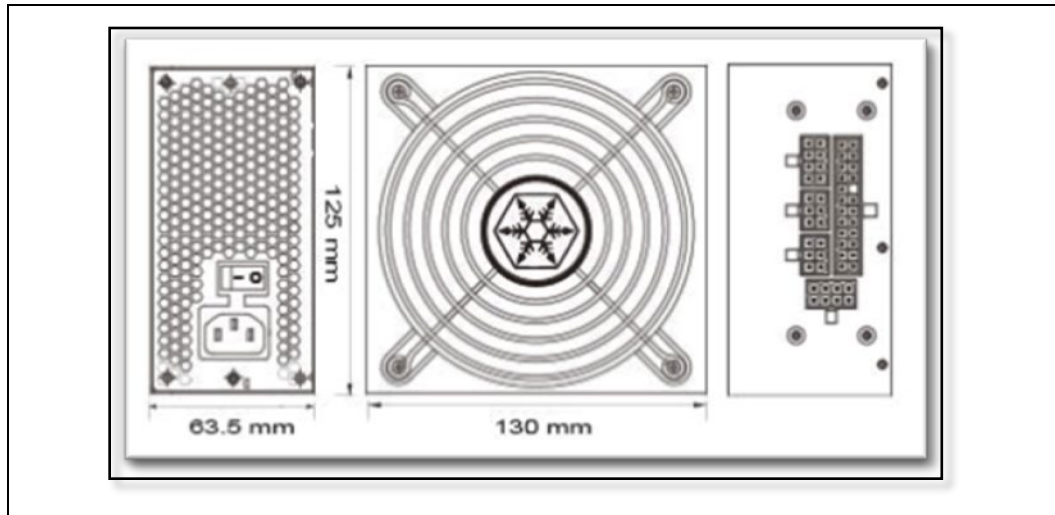
Figure 14-8. Moving the fan to the computer system cavity helps to limit the acoustic noise of the unit.

The fan will be 80 mm.

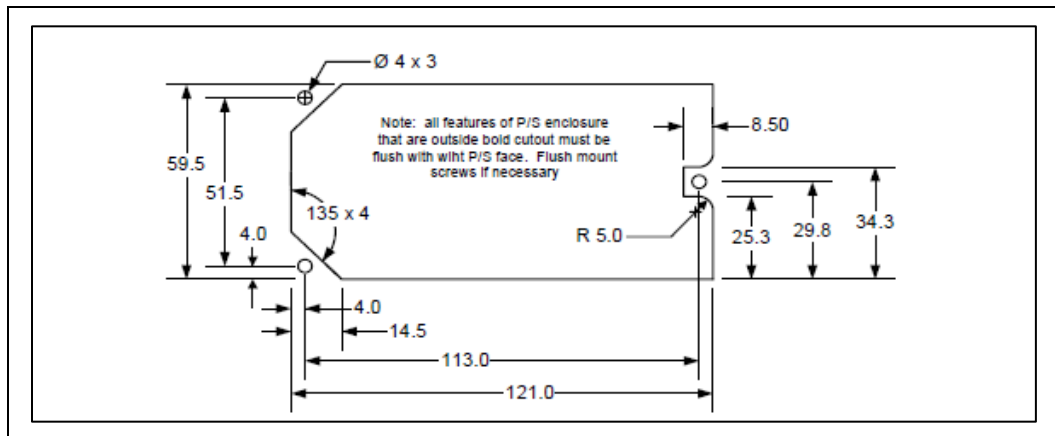
Figure 14-6: SFX12V Reduced Depth Top Mount Fan Profile Mechanical Outline



**Figure 14-7: SFX12V Top Mount Fan, Inside enclosure Mechanical Outline (Possible Larger Fan)**



**Figure 14-8: SFX12V Chassis Cutout**



## 14.7 Standard SFX Profile Package – Physical Dimensions (Required)

The power supply shall be enclosed and meet the physical outline shown in the above figure.

## 14.8 Fan Requirements (Required)

The fan will draw air from the computer system cavity pressurizing the power supply enclosure. The power supply enclosure shall exhaust the air through a grill located on the rear panel. Refer to the below figure. The movement of the fan to the computer system cavity is to help limit the acoustic noise of the unit.

The fan will be 60 mm.

Figure 14-9: SFX12V 60 mm Mechanical Outline

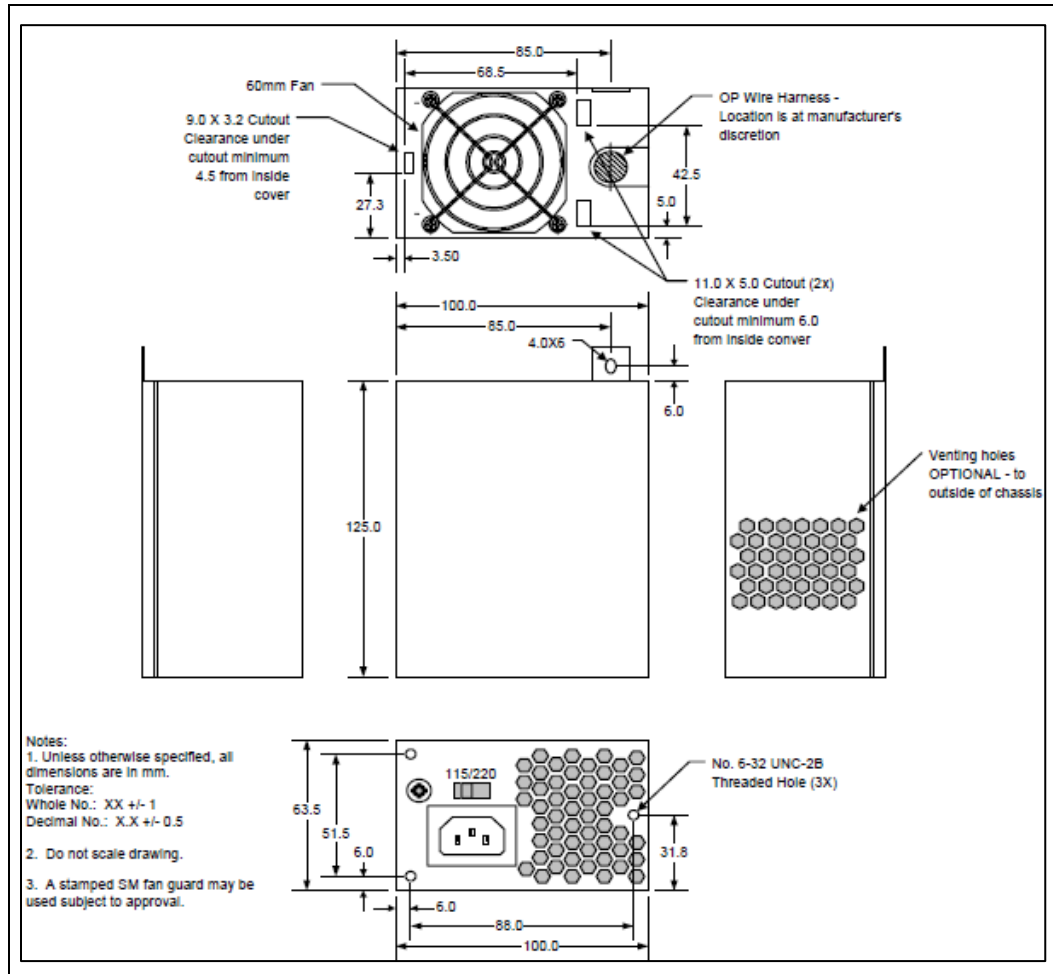
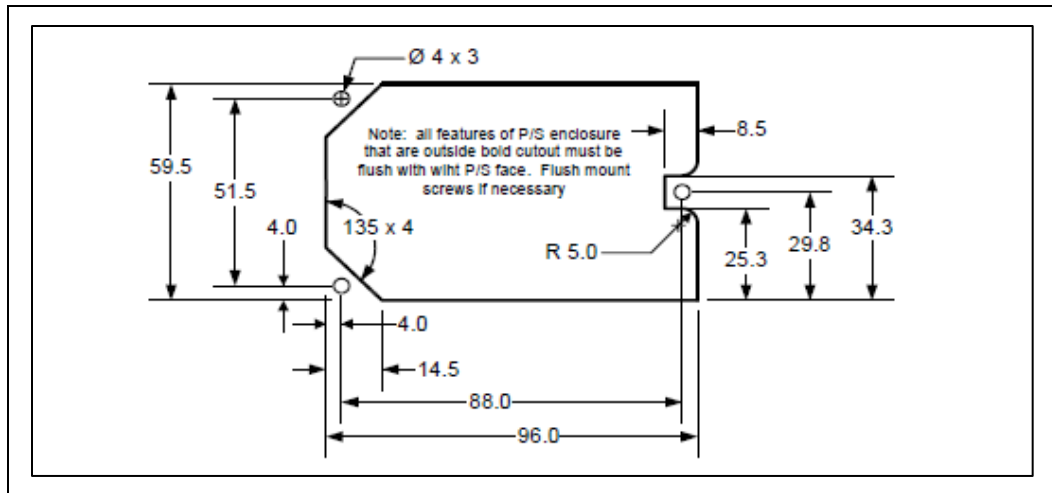


Figure 14-10: SFX12V Chassis Cutout



## 14.9 PS3 Form Factor – Physical Dimensions (Required)

The power supply shall be enclosed and meet the physical outline shown in [Figure 14-11](#).

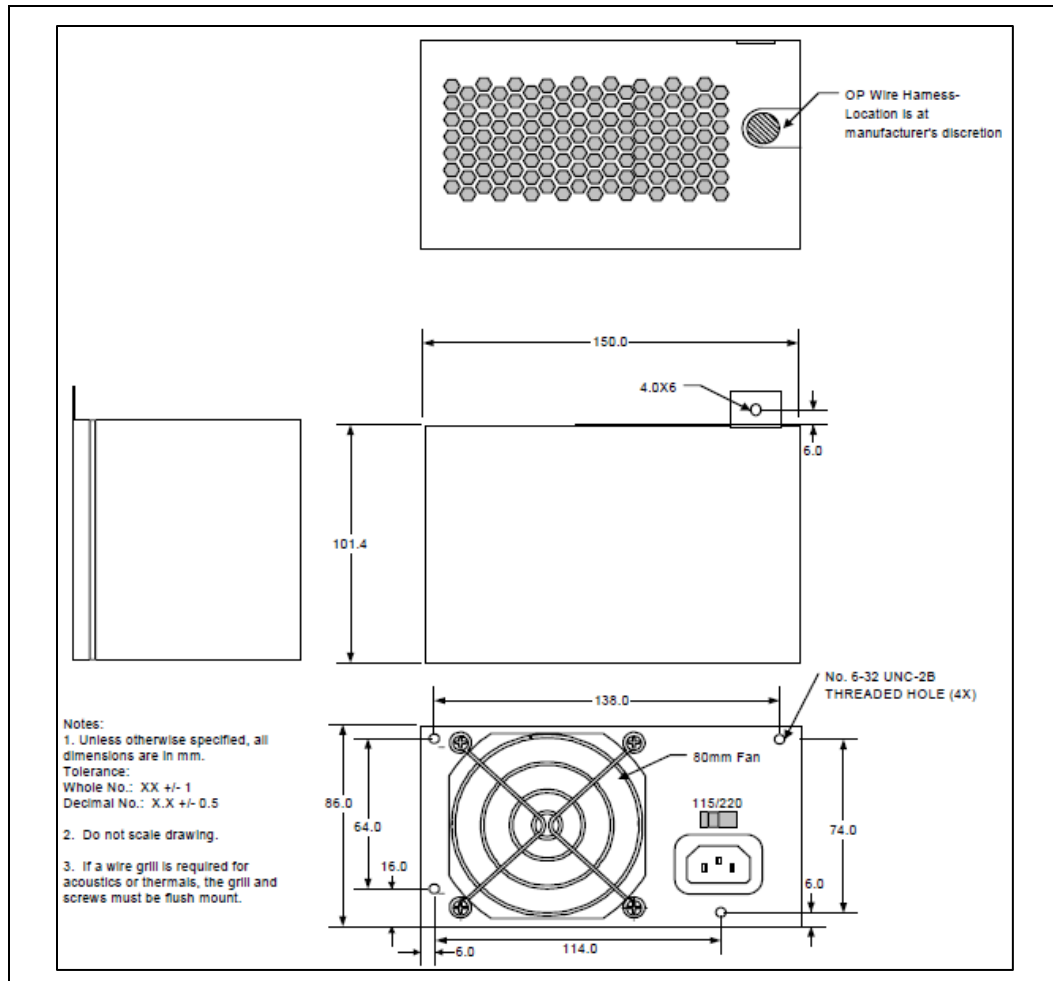
## 14.10 Fan Requirements (Required)

An 80 mm axial fan is typically needed to provide enough cooling airflow through a high performance Micro ATX system. Exact CFM requirements vary by application and end user environment, but 25-35 CFM is typical for the fan itself.

For consumer or other noise-sensitive applications, it is recommended that a thermally sensitive fan speed control circuit be used to balance system-level thermal and acoustic performance. The circuit typically senses the temperature of an internal heatsink and/or incoming ambient air and adjusts the fan speed as necessary to keep power supply and system component temperatures within specification. Both the power supply and system designers should be aware of the dependencies of the power supply and system temperatures on the control circuit response curve and fan size and should specify them very carefully.

The power supply fan should be turned off when PS\_ON# is de-asserted (high). In this state, any remaining active power supply circuitry must rely only on passive convection for cooling.

Figure 14-11: SFX12V PS3 Mechanical Outline



§§

# 15 TFX12V Specific Guidelines 3.0

For Thin Form Factor with 12-volt connector power supplies.

Mechanical dimension of power supplies has not changed from Multi Rail Desktop Power Supplies, so chassis do need not to change. Below are the current specifications for each size:

PSU DG	CFX12V	LFX12V	ATX12V	SFX12V	TFX12V	Flex ATX
2.0	2.0	2.0	3.0	4.0	3.0	2.0

## 15.1 Physical Dimensions (Required)

Figure 15-1: TFX12V Mechanical Outline

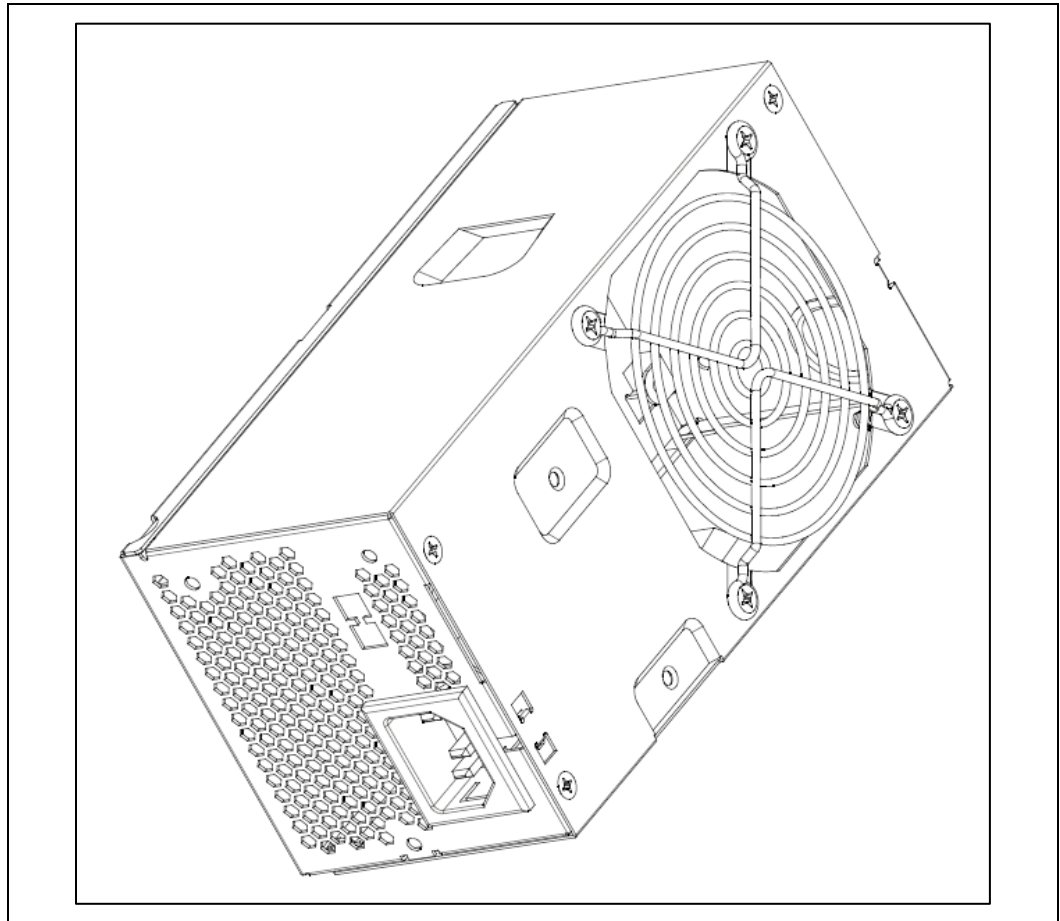


Figure 15-2: TFX12V Dimensions and Recommended Feature Placements (Not to Scale)

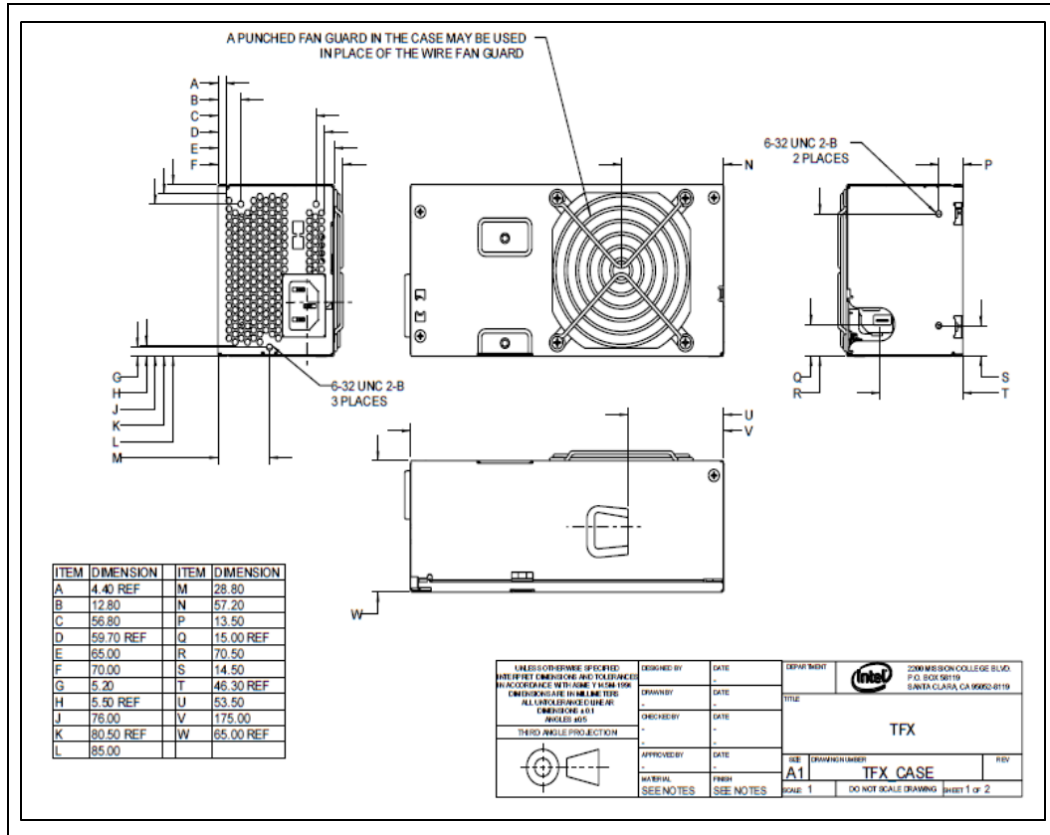
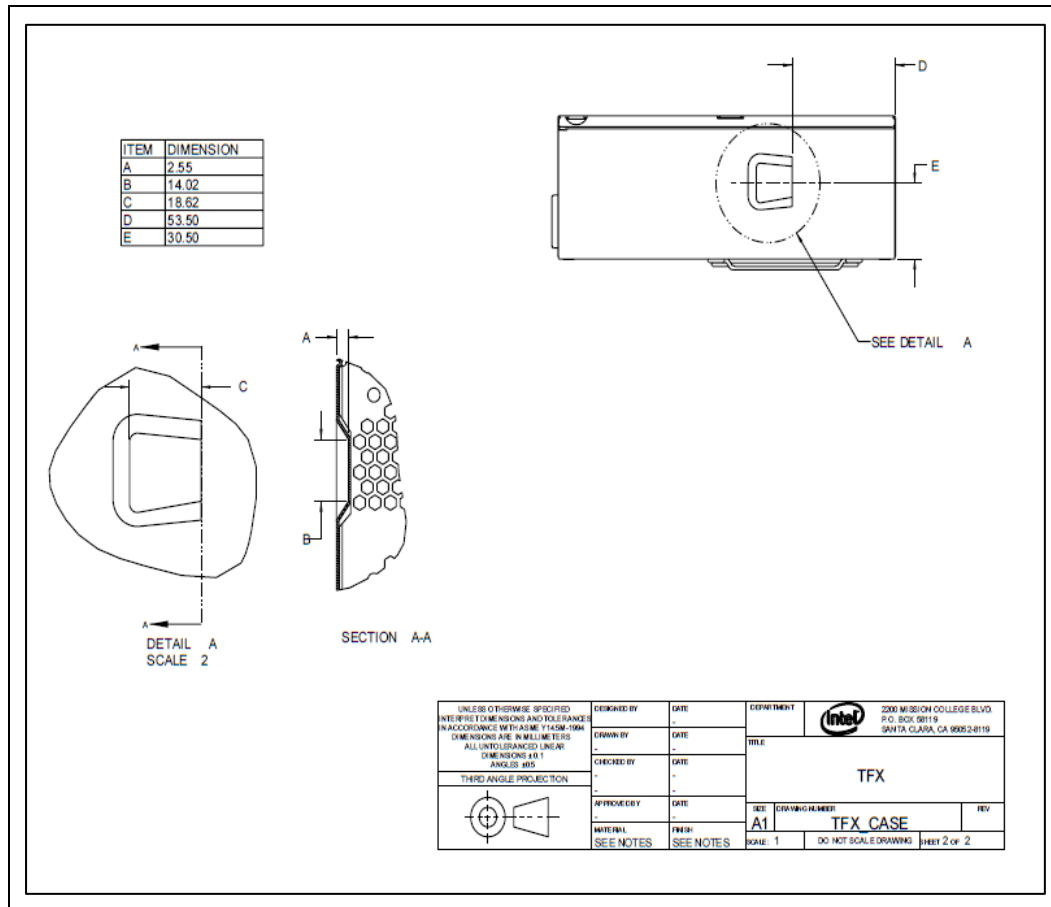




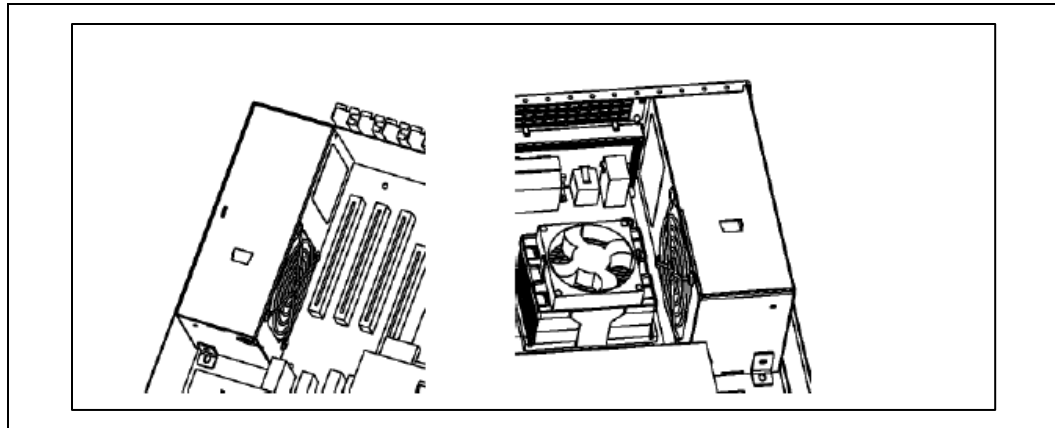
Figure 15-3: TFX12V Power Supply Mounting Slot Detail



## 15.2 Mounting Options (Recommended)

The TFX12V mechanical design provides two options for mounting in a system chassis. The unit can be mounted using one of the mounting holes on the front end (non-vented end) or a chassis feature can be designed to engage the slot provided in the bottom of the supply. To accommodate different system chassis layouts, the TFX12V power supply is also designed to mount in two orientations (fan left and fan right) as shown in [Figure 15-4](#). A mounting hole and slot should be provided for each orientation as shown in [Figure 15-2](#). Details of a suggested geometry for the mounting slot are shown in [Figure 15-3](#).

Figure 15-4: TFX12V Fan Right and Fan Left Orientations of Power Supply in Chassis



### 15.3 Chassis Requirements (Recommended)

To ensure the power supply can be easily integrated, the following features should be designed into a chassis intended to use a TFX12V power supply:

- Chassis cutout (normally in the rear panel of the chassis) as shown in the figure below.
- EITHER a mounting bracket to interface with the forward mounting hole on the power supply OR a mounting tab as shown in [Figure 15-6](#) to interface with the mounting slot on the bottom of the power supply.

Figure 15-5: Suggested TFX12V Chassis Cutout

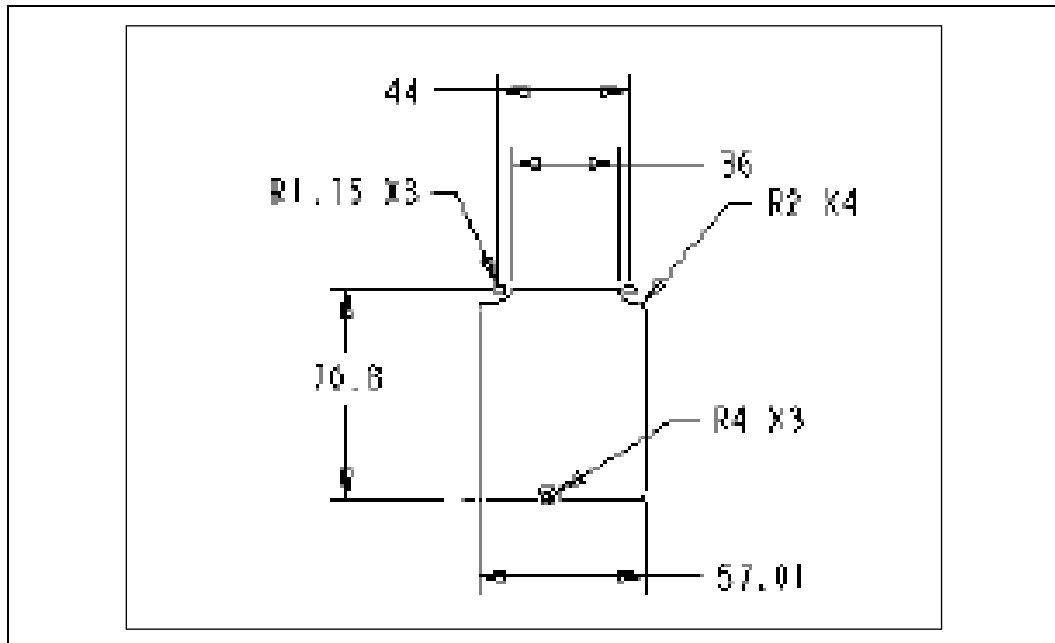
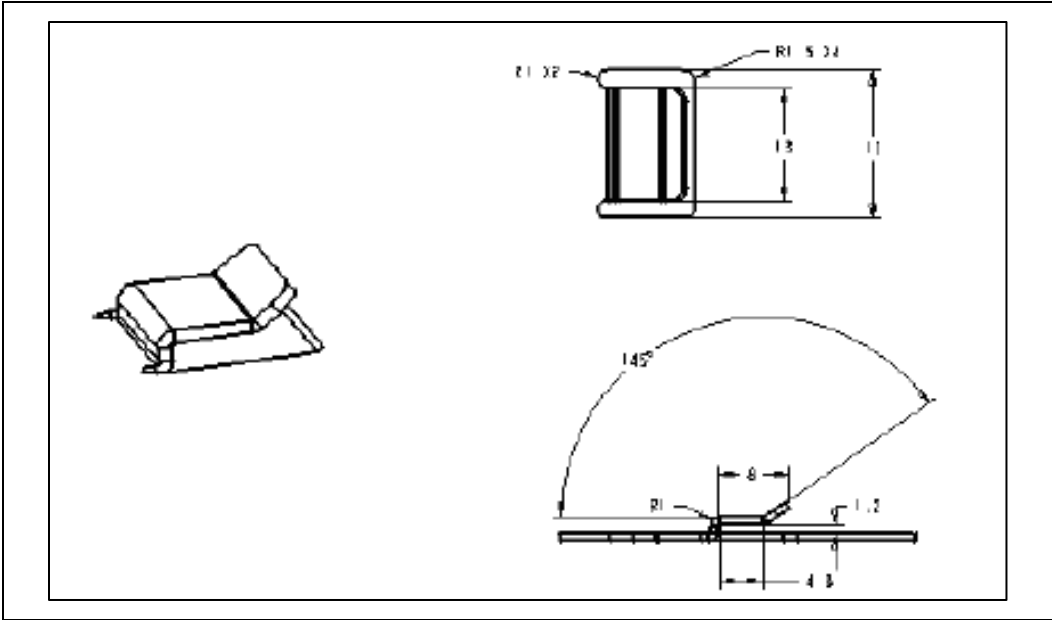


Figure 15-6: TFX12V Suggested Mounting Tab (Chassis Feature)



§§

# 16 Flex ATX Specific Guidelines 2.0

For Flex ATX Form Factor with 12-volt connector power supplies.

Mechanical dimension of power supplies has not changed from Multi Rail Desktop Power Supplies, so chassis do need not to change. Below are the current specifications for each size:

PSU DG	CFX12V	LFX12V	ATX12V	SFX12V	TFX12V	Flex ATX
2.0	2.0	2.0	3.0	4.0	3.0	2.0

## 16.1 Physical Dimensions (Required)

Figure 16-1: Flex ATX Mechanical Outline

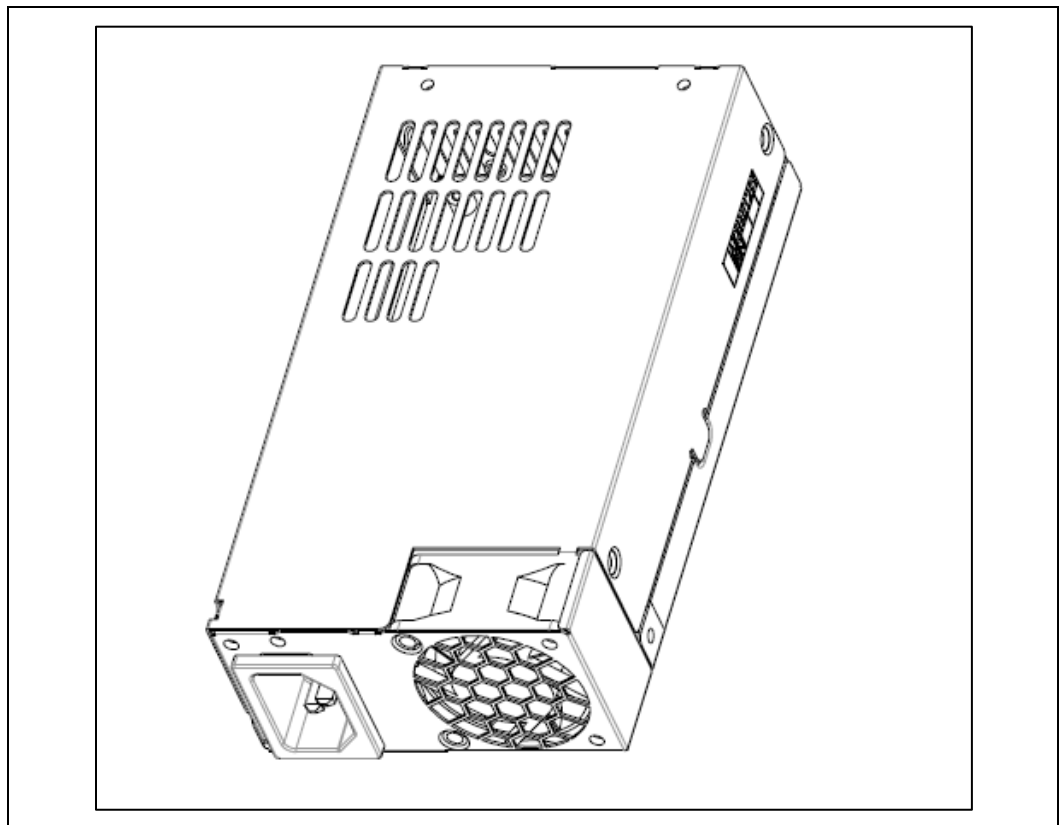
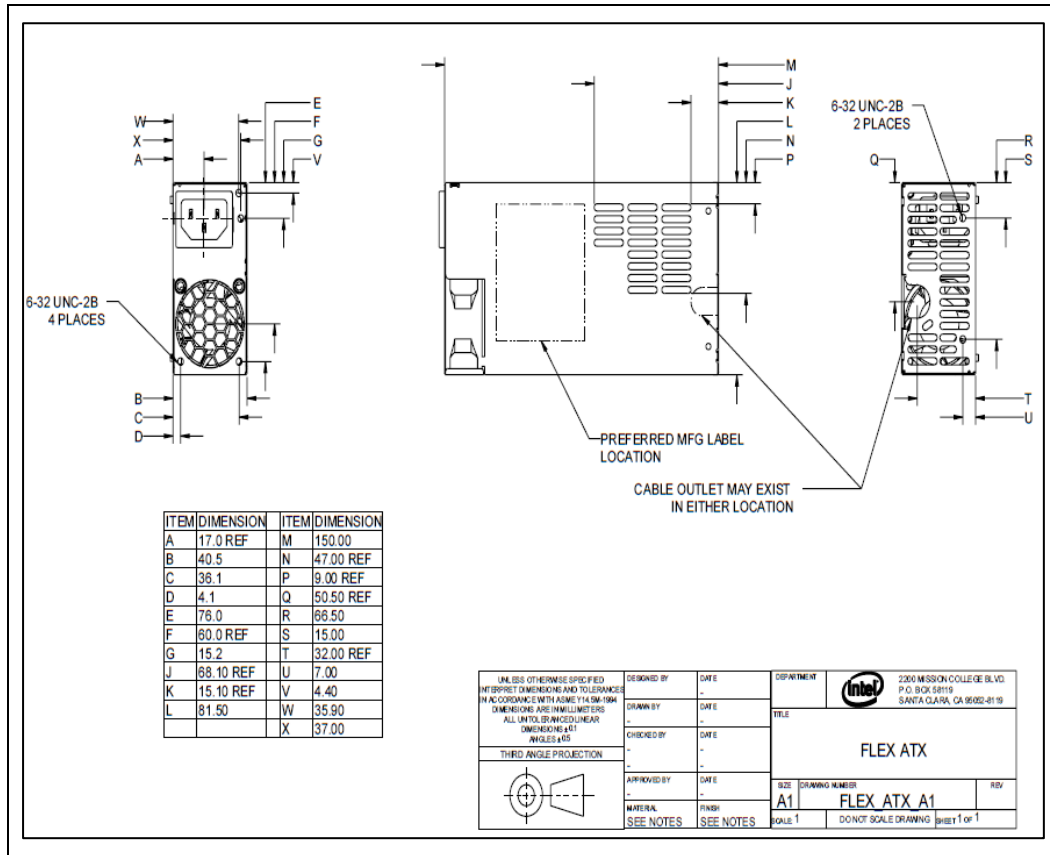


Figure 16-2: Flex ATX Dimensions and Recommended Feature Placements (Not to Scale)



SS